

ARQUITEK 
Decorative Panels

Nuestra Empresa Our Company	2-3
Nuestras Instalaciones Facilities	4-5
Calidades Qualities	6-7
Ventajas Advantages	8
Sostenibilidad Sustainability	8-13

Arquitek Collection

SLIM	ALMA	INNER
MILO	MODUS	RINN
ICON	NEOS	BLOM
SPIRIT	SCALON	VITA
ARKO	LOUN	PERFILES

Información Técnica Technical Information	122
Garantía Warranty	122
Condiciones de venta Sales Terms	123
Tarifa/Rate	124

Nuestra Empresa Our Company

PANELPIEDRA®
en el mundo
in the world

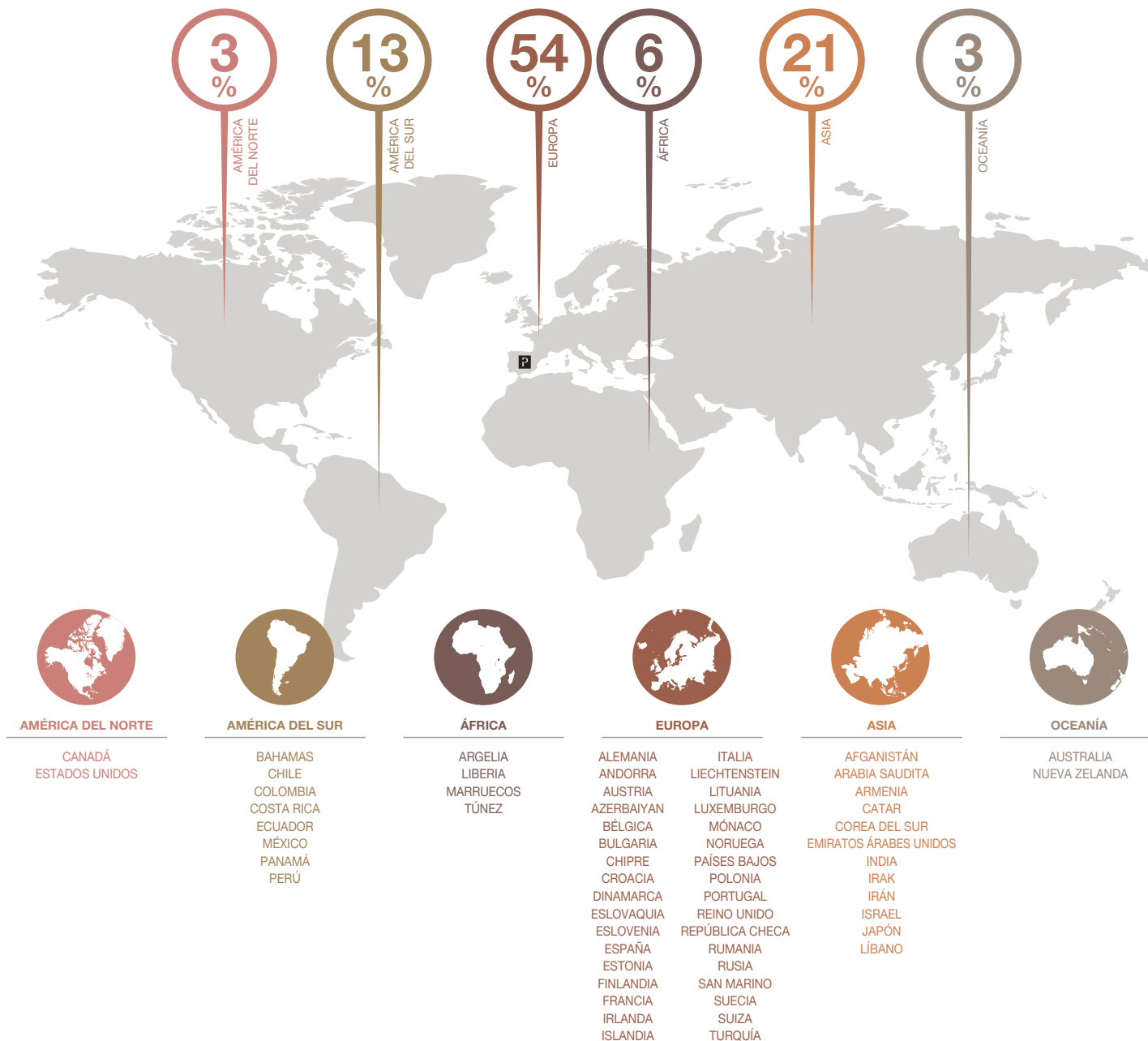

En sus 50 años de trayectoria Paneles Decorativos Panel Piedra ha centrado sus esfuerzos en ofrecer un producto de calidad y diseño claramente orientado a satisfacer las necesidades del cliente. Gracias al esfuerzo de todos estos años y a una acertada gestión empresarial, PANELPIEDRA® está presente en más de 60 países. Actualmente, su misión es crear espacios que contribuyan al bienestar a través del diseño, la funcionalidad y las tecnologías revestimiento.

Su estrategia está fuertemente marcada por la innovación dirigida tanto al producto como a la gestión de la empresa. Su objetivo es seguir imprimiendo un alto valor añadido que le permita la diferenciación con la competencia en los distintos mercados, y contribuir a mejorar la calidad de vida de sus clientes. La historia de esta empresa es la de la superación, el esfuerzo, la confianza y el trabajo en equipo. En todos estos años ha ido evolucionando paso a paso hasta llegar al punto de liderazgo que hoy ostenta PANELPIEDRA®.

In its 50 years of trajectory Paneles Decorativos Panel Piedra has always focused its efforts on offering a quality product and design, clearly oriented to satisfy customer needs. Thanks to the efforts of all these years and successful business management, PANELPIEDRA® is available in more than 60 countries. Currently, its mission is to create spaces that contribute to well-being through design, functionality and cladding technologies.

Its strategy is strongly marked by innovation directed both to the product and to the management of the company. Its objective is to continue to manufacture a high added value that allows it to differentiate itself from the competition in different markets and to contribute to improving the quality of life of its customers. The history of this company is one of fortuitous, effort, trust and teamwork. In all these years it has evolved step by step to reach the point of leadership that PANELPIEDRA® holds today.



PANELPIEDRA® dispone de un gran centro de fabricación en Tudela, Navarra, España. Con modernas y preparadas instalaciones de 170.000 m².

PANELPIEDRA® have a large manufacturing center in Tudela, Navarra, Spain With modern and prepared facilities of 170.000 m².

PANELES DECORATIVOS
PANELPIEDRA S.L.
Polígono Industrial Municipa
Vial Transversal, 2
31500 TUDELA (NAVARRA) SPAIN
T. +34 941 18 10 91
www.panelpiedra.com



Nuestras Instalaciones Facilities

OFICINAS

2.000 m2 de modernas oficinas y espacio expositivo, con una división perfectamente departamentada para ofrecer la mejor atención a los 52 países donde tenemos presencia comercial.

OFFICES

2.000 Sqm of offices and Showroom in order to offer the best possible customer service to all our clients, spread across 52 countries.

EXPOSICIÓN

Más de 1.000 m² destinados a nuestro showroom, con paneles de revestimientos y de mobiliario de baño.

EXHIBITION

With more than 1.000 m² destined to the exhibition of our cladding tiles and bathroom furniture products.



LAB E INGENIERÍA

Todos nuestros productos y materiales pasan un exhaustivo control de calidad en nuestros laboratorios, todo ello es precedido por una amplia labor de investigación y desarrollo llevada a cabo por el Departamento de Ingeniería, donde se trabaja para alcanzar los estándares de calidad e innovación que caracterizan nuestra marca PANELPIEDRA®

LAB AND ENGINEERING

All our products and materials pass an exhaustive quality control in our laboratories, all this is preceded by extensive research and development carried out by the Engineering Department, where we work to achieve the quality and innovation standards that characterize our PANELPIEDRA® brand.



PRODUCCIÓN

Miles de metros cuadrados de industria, dedicados a la fabricación de paneles decorativos para interior y exterior, mobiliario de baño, platos de ducha y lavabos (solid surface). Con zonas de modelado, de mezclas, de producción, de acabados, de secado y de inspección de calidad. **Todo preparado para que nuestro proceso de producción sea eficaz y de alta calidad.**

PRODUCTION

Thousands of sqm of manufacturing capacity with different departments for moulding, mixing, manufacturing, finishing, drying and quality inspection. **With the purpose of producing our products (wall covering panels for interior and exterior, bathroom furniture, shower trays, solid surface).**



ZONA DE EMBALAJE Y ALMACÉN

Una gran organización de nuestros productos, tanto en el embalaje como en el almacenaje, hacen que nuestros pedidos tengan un seguimiento continuo de calidad hasta su entrega.

PACKING & STORAGE AREA

A well organised packing and storage area in order to have a great follow up of clients' orders and keepup the high quality until delivery.



Calidades Qualities

Nuestra dedicación constante a la investigación tecnológica nos ha permitido desarrollar un producto perfecto y vanguardista en un campo en constante evolución, como es el mundo de la decoración y el diseño.

Ofrecemos las mejores soluciones estéticas para las últimas tendencias en diseño e interiorismo, cada vez más iconoclasta en la combinación de formas, colores y materiales.

Nuestros sistemas de fabricación patentados nos permiten una reproducción fiel de texturas y tonos de piedras, ladrillos, cementos y maderas, pero además la facilidad de instalación, resistencia y calidad convierten a nuestro producto en uno de los más demandados por los profesionales del sector.

La utilización de los productos PANELPIEDRA® permite crear ambientes que combinan elegancia, diseño y calidad.

Our ongoing commitment to technological research allowed us to develop a cutting edge product within a constantly evolving industry, as it is the world of decoration and design.

We offer the best aesthetic solutions for the latest trends in interior design and, increasingly iconoclastic combination of shapes, colors and materials.

Our patented manufacturing systems allow us to faithfully reproduce textures and colors of stones, bricks cement and woods. The easy installation, strength and high quality of our products, makes them highly demanded by professionals.

The use of PANELPIEDRA® products allow customers to create atmospheres that combine elegance, quality and design.

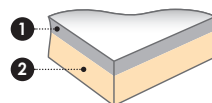

1. Polvo de mármol (Piedra) /
Crushed marble stone
2. Poliuretano alta densidad /
High density injected polyurethane

**NUEVO
NEW**

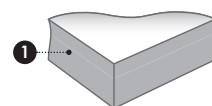

1. Polvo de mármol (Piedra) - Panel Aligerado /
Crushed marble stone - Lightened Panel

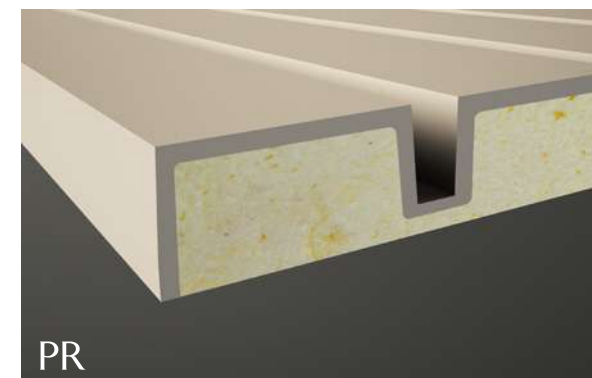

PR

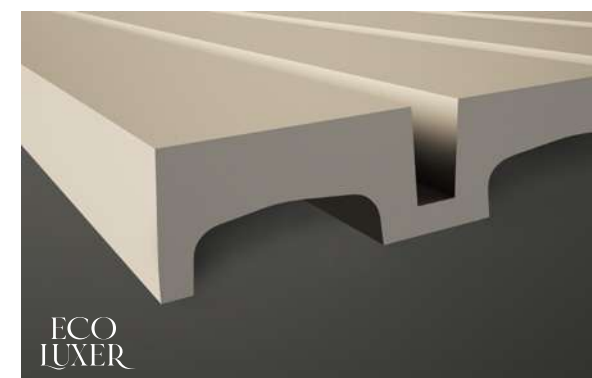

ECO
LUXER



Paneles compuestos en un
75% por material reciclable sobrantes de canteras.

Panels composed of
75% recyclable material from quarries.



Panel de poliuretano con piedra.

Panel compuesto por una capa de 4 mm. (aprox.) de polvo de mármol (piedra) y una capa de inyección de poliuretano de alta densidad.

Todo ello hace que sea muy resistente a todo tipo de inclemencias climatológicas (lluvia, sol, heladas, niebla, salina, etc.) Es apto para su colocación en interior y en exterior. Excelentes propiedades saliente térmicas, acústicas y anti-humedad.

Polyurethane and stone panel.

Panel composed of a layer of approximately 4 mm of crushed marble stone and a layer of high density injected polyurethane.

These components makes it very resistant to all kinds of weather conditions (rain, sun, frost, fog, salt, etc.).

Suitable for indoors and outdoors installations. Excellent thermal, acoustic and anti-humidity characteristics.



Panel EcoLuxer®.

Panel compuesto de polvo de mármol (piedra) aligerado.

EcoLuxer® es un producto innovador para revestimientos de todo tipo de paredes, muros y techos, compuesto con más de 16 tipos de cargas, minerales y químicas (piedra, mármol, sílices, silicatos, etc.) que lo hacen muy resistentes al exterior, al fuego y todo tipo de inclemencias climatológicas en el tiempo, como a su vez gran resistencia a la abrasión y productos químicos. También goza de una gran cualidad que es su bajo peso y su alto volumen, que todo ello hace que sea muy fácil su colocación.

Es muy apto para lugares públicos de gran tránsito de personas, fachadas y grandes construcciones, lugares con mucha humedad, saunas, etc.

Excelentes propiedades ignífugas, hidrófugas, su inalterabilidad al choque térmico y a sus ciclos de hielo y deshielo, su nulo porcentaje de absorción de agua garantiza su completa estanqueidad, su alta resistencia a la mayoría de productos químicos, junto con su mínimo desgaste por abrasión, hacen que el producto EcoLuxer® sea un material de alta calidad extra.

EcoLuxer® Panel.

Panel composed of crushed marble stone lighter.

EcoLuxer® is a highly innovative panel for coating all types of walls and ceilings. It is made out of more than 16 types of mineral and chemical charges (ie: stone, marble, silica, silicates, etc.). This composition makes the panel suitable to exteriors, resistant to fire and all kind of weather. Also, it has great resistance to abrasion and chemicals. Its low weight and large size makes the installation very quick and easy. Suitable for public places and areas of high traffic of people, facades, large buildings, places with high humidity (ie: saunas), etc.

Excellent fire retardant, water repellent, resistant to heat, freeze and defrost. Its zero percent water absorption ensures a complete sealing. High resistance to most chemicals products and low abrasive wear. All these characteristics make HD® panel a extra high quality material.

Ventajas Advantages



- El panel más ligero del mercado.
- Instalación más fácil y sencilla.
- Paneles de colocación rápida.
- Importante ahorro en costes.
- Acabado perfecto.
- No necesita mantenimiento.
- Excelente aislamiento acústico.
- Buen aislamiento térmico y anti-humedad.
- Excelentes propiedades ignífugas.
- Excelente repelencia al agua.
- No se altera con el calor, el frío o la congelación.
- Material impermeable.
- Mínima abrasión.
- Alta resistencia a la mayoría de los productos químicos.
- Elegantes combinaciones de materiales y diseños.
- Facilidad de transporte y manejo

- The lightest panel in the market.
- Easy and simple installation.
- Quick installation system.
- Cost savings in labor.
- Perfect finish.
- Does not require maintenance
- Excellent soundproof qualities.
- Good thermal insulation and anti-humidity.
- Excellent flame retardant properties.
- Excellent water-repellent.
- No mutation to heat, freeze and defrost.
- Not permeable.
- Minimum abrasion.
- High resistance to most chemicals.
- Elegant combinations of materials and designs.
- Ease of transport and handling.

Sostenibilidad Sustainability

POR UNA MEJOR CALIDAD DE VIDA Y CONSERVACIÓN DEL MEDIO AMBIENTE.

En Paneles Decorativos PanelPiedra® sabemos que siempre debemos estar en continua evolución, mejorando la calidad de vida y conservando la naturaleza y el medio ambiente.

Nos centramos en aumentar el impacto positivo de nuestros paneles, fabricando con un 75% de materiales reciclables, polvo de mármol y restos de canteras. Nos comprometemos a mejorar continuamente la sostenibilidad de nuestra empresa.

La protección de la naturaleza y la mejora de la calidad de vida de las personas es el impulso que nos lleva a seguir investigando y mejorando.





FOR A BETTER QUALITY OF LIFE AND ENVIRONMENTAL CONSERVATION.

At PanelPiedra® Decorative Panels we know that we must always be in continuous evolution, improving the quality of life and conserving nature and the environment.

We focus on increasing the positive impact of our panels, manufacturing with 75% recyclable materials, marble dust and quarry waste. We are committed to continuously improve the sustainability of our company.

The protection of nature and the improvement of people's quality of life is the driving force behind our continuous research and improvement.

1. NUESTRAS RESINAS

EN NUESTRAS RESINAS UTILIZAMOS MATERIALES RECICLADOS DE BOTELLAS DE PLÁSTICO PET.

En Paneles Decorativos PanelPiedra® utilizamos resinas de poliéster y poliuretano con una cantidad muy elevada de **botellas de plástico recicladas.**

Cada metro cuadrado de nuestras resinas contiene al menos 1/3 de botellas de plástico recicladas.



1. OUR RESINS

IN OUR RESINS WE USE RECYCLE MATERIALS SUCHAS PLASTIC PET BOTTLES.

In Paneles Decorativos PanelPiedra® we use polyester and polyurethane resins with a very high quantity of **recycled plastic bottles.**

Each square meter of our resins contains at least 1/3 recycled plastic bottles

2. DESARROLLO SOSTENIBLE

Nuestras instalaciones disponen de depuradoras y procesos manuales para evitar el consumo excesivo de agua.

Nuestra materia prima consiste en un 75% de material reciclable, polvo de mármol y restos de canteras. Nos preocupa la contaminación y la incidencia de residuos como el plástico, por lo que utilizamos cartón reciclable en nuestros envases y así contribuir a la protección de la tierra y los océanos, ya que la biodiversidad marina es vital para la salud de las personas y de nuestro planeta.

Queremos conservar la naturaleza, adaptando todos los procesos de fabricación, para minimizar el impacto de nuestra actividad en el medio ambiente.

Intentamos generar los mínimos residuos posibles optimizando el uso de las materias primas. Los grosores de los paneles están cuidadosamente estudiados para evitar dimensiones innecesarias, minimizando los residuos sin afectar a su diseño ni calidad.

Nuestros productos están fabricados para una gran durabilidad, pueden ser repintados, esto permite reciclar el propio producto y pueden ser retirados y reinstalados en otros espacios por lo tanto es un producto reutilizable.



2. SUSTAINABLE DEVELOPMENT

Our facilities are equipped with purifiers and manual processes to avoid excessive water consumption.

Our raw material consists of 75% recyclable material, marble dust and quarry waste. We are concerned about pollution and the incidence of waste such as plastic, so we use recyclable cardboard in our packaging and thus contribute to the protection of land and oceans, as marine biodiversity is vital for the health of people and our planet.

We want to conserve nature by adapting all our manufacturing processes to minimise the impact of our activity on the environment.

We try to generate as little waste as possible by optimising the use of raw materials. The thicknesses of the panels are carefully studied to avoid unnecessary dimensions, minimising waste without affecting their design and quality.

Our products are manufactured for durability, they can be repainted, this allows the product itself to be recycled and they can be removed and reinstalled in other spaces, therefore it is a reusable product.



3. MATERIA PRIMA

En Paneles Decorativos PanelPiedra® estamos comprometidos con la continua mejora sostenible de nuestros productos, innovando en la seguridad de cada uno de los procesos.

El poliuretano, como nuestra materia prima, posee una serie de características que confieren a nuestros productos propiedades colaborativas con el medio ambiente.

3. RAW MATERIAL

At PanelPiedra® Decorative Panels we are committed to the continuous sustainable improvement of our products, innovating in the safety of each of our processes.

Polyurethane, as our raw material, has a series of characteristics that give our products environmentally friendly properties.



4. REDUCCIÓN DE CONSUMO DE ENERGÍA

El poliuretano es un eficaz aislante térmico, proporcionando además aislamiento acústico. Los paneles decorativos de PanelPiedra® cuentan con el certificado de Aislamiento Térmico según la normativa UNE.

Como eficaces aislantes, mejoran la eficiencia energética de los edificios y reducen la necesidad de calefacción y refrigeración, reduciendo así las emisiones de carbono.

Las Declaraciones Ambientales de Producto (DAP) proporcionan información cuantitativa sobre los impactos ambientales de un producto a lo largo de su vida útil. La Voz Europea del Poliuretano (PU Europe) ha llevado a cabo un análisis ambiental y económico del ciclo de vida del poliuretano como aislante en edificios de consumo de energía casi nulo en el que se determina que el poliuretano es una solución material altamente eficiente dado su bajo coste del ciclo de vida.



4. REDUCTION OF ENERGY CONSUMPTION

Polyurethane is an effective thermal insulator, also providing noise insulation. The decorative panels of PanelPiedra® have the certificate of Thermal Insulation according to the regulations UNE.

As effective insulators, they improve the energy efficiency of buildings and reduce the need for heating and cooling, thereby reducing carbon emissions.

Environmental Product Declarations (EPDs) provide quantitative information on the environmental impacts of a product throughout its life. The European Voice of the Polyurethane (PU Europe) has carried out an environmental and economic life cycle analysis of polyurethane as an insulator in nearly zero energy buildings where polyurethane is determined as a highly efficient material solution given its low life cycle cost.

5. REVESTIMIENTO IGNÍFUGO

Por su naturaleza, el poliuretano no genera gases ni humos asfixiantes y no es tóxico en contacto con el fuego, aumentando así la protección de personas y bienes.

Al mismo tiempo, los Paneles Decorativos PanelPiedra® están fabricados con un recubrimiento ignífugo acreditado según las normas UNE, que establece que los paneles no arden, y aguantan hasta 80° de temperatura hasta que comienzan a deformarse de forma cóncava.

Gracias a años de intensa investigación, todos nuestros productos cumplen con la normativa internacional en materia de seguridad contra incendios.

5. FLAME RETARDANT COATING

By its nature, polyurethane does not generate gases or asphyxiating fumes and is not toxic when it comes into contact with fire, thus increasing the protection of people and property.

At the same time, PanelPiedra® decorative panels are manufactured with a fire proof coating accredited by the certificate according to the UNE, which states that the panels do not burn, and hold up to 80° of temperature until they begin to deform concavely.

Thanks to years of intensive research, all our products comply with international regulations in fire safety agreements, in the EU and in Russia, USA, Australia and New Zealand.

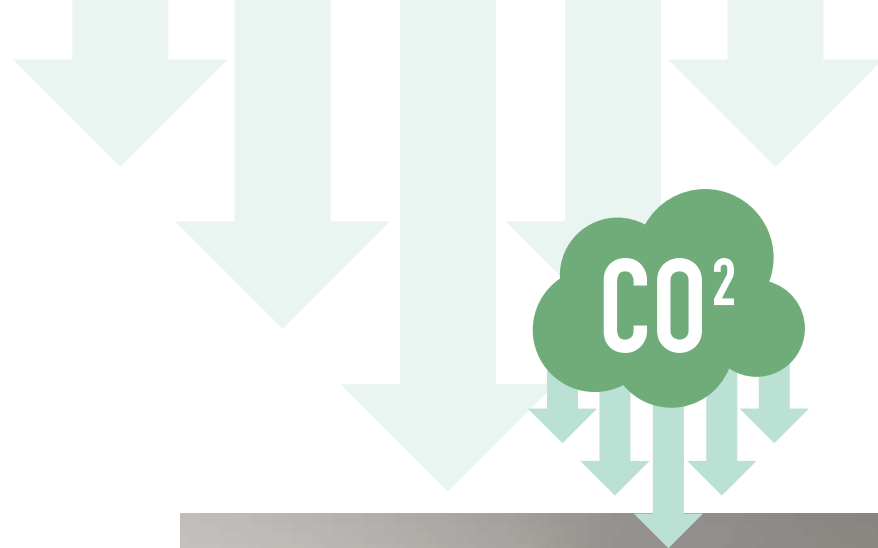

6. REDUCCIÓN DE LA HUELLA DE CARBONO

Nuestro compromiso con el medioambiente para reducir la huella de carbono es total. Desarrollamos un avanzado plan de acción climática midiendo la huella de carbono de los últimos años lo que nos permitirá reducir, e incluso neutralizar, los impactos generados por nuestra actividad comercial.

Las emisiones inevitables de gases de efecto invernadero (huella de carbono cuya reducción no es viable) serán compensadas a través de la adquisición de créditos de carbono. De este modo, en PanelPiedra® nos comprometemos a convertirnos en una empresa 100% Neutra en Carbono en los próximos años.

6. CARBON FOOTPRINT REDUCTION

Our commitment to the environment to reduce our carbon footprint is total. We have developed an advanced climate action plan by measuring our carbon footprint over the last few years, which will enable us to reduce and even neutralise the impacts generated by our business activity.

Unavoidable greenhouse gas emissions (carbon footprint whose reduction is not feasible) will be offset through the acquisition of carbon credits, thus, at PanelPiedra® we are committed to becoming a 100% Carbon Neutral company in the coming years.



AR

QU

TEK



Arquitek
Collection

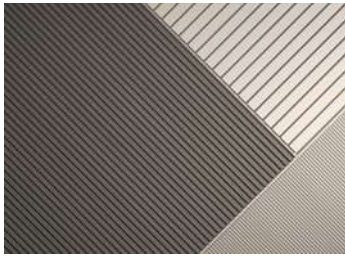

SLIM 18



MILO 28



ICON 34



SPIRIT 42



ARKO 48



ALMA 56



MODUS 62



NEOS 70



SCALON 76



LOUN 84



INNER 92



RINN 100



BLOM 106



VITA 112











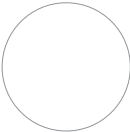

PERFILES 118

* Especificaciones para los ACABADOS de COLORES: pág. 16-17

* Specifications for COLOUR FINISHES pages 16-17

Especificaciones para los Acabados de Colores

Specifications for Colour Finishes

  <p>Ref.1 BLANCO WHITE</p>	<p>Complementos necesarios para la instalación / Necessary materials for installation</p> <ul style="list-style-type: none"> ○ MSA-110 Masilla Juntas Blanco Roto - Bote 1,8 Kg ○ PTX-20-400 Pintura Juntas Blanco Roto <p>+Complementos opcionales para la instalación / Optional materials for installation</p> <ul style="list-style-type: none"> ○ MSA-3-280 Masilla de Pegado 	<p>Rendimiento Aproximado / Average Usage</p> <p>1 Bote cada 8/10 paneles 1 Bote cada 8 paneles</p> <p>1 Bote cada 4 paneles</p>
  <p>Ref.15 HUESO BONE</p>	<p>Complementos necesarios para la instalación / Necessary materials for installation</p> <ul style="list-style-type: none"> ○ MSA-110 Masilla Juntas Blanco Roto - Bote 1,8 Kg ● PTX-101-400 Pintura Juntas Hueso Acabado Liso <p>+Complementos opcionales para la instalación / Optional materials for installation</p> <ul style="list-style-type: none"> ○ MSA-3-280 Masilla de Pegado 	<p>Rendimiento Aproximado / Average Usage</p> <p>1 Bote cada 8/10 paneles 1 Bote cada 8 paneles</p> <p>1 Bote cada 4 paneles</p>
  <p>Ref.2 CREMA CREAM</p>	<p>Complementos necesarios para la instalación / Necessary materials for installation</p> <ul style="list-style-type: none"> ○ MSA-110 Masilla Juntas Blanco Roto - Bote 1,8 Kg ● PTX-93-400 Pintura Juntas Crema Acabado Liso <p>+Complementos opcionales para la instalación / Optional materials for installation</p> <ul style="list-style-type: none"> ○ MSA-3-280 Masilla de Pegado 	<p>Rendimiento Aproximado / Average Usage</p> <p>1 Bote cada 8/10 paneles 1 Bote cada 8 paneles</p> <p>1 Bote cada 4 paneles</p>
  <p>Ref.3 CEMENTO CONCRETE</p>	<p>Complementos necesarios para la instalación / Necessary materials for installation</p> <ul style="list-style-type: none"> ○ MSA-110 Masilla Juntas Blanco Roto - Bote 1,8 Kg ● PTX-94-400 Pintura Juntas Cemento Liso <p>+Complementos opcionales para la instalación / Optional materials for installation</p> <ul style="list-style-type: none"> ○ MSA-3-280 Masilla de Pegado 	<p>Rendimiento Aproximado / Average Usage</p> <p>1 Bote cada 8/10 paneles 1 Bote cada 8 paneles</p> <p>1 Bote cada 4 paneles</p>
  <p>Ref.4 ARENA SAND</p>	<p>Complementos necesarios para la instalación / Necessary materials for installation</p> <ul style="list-style-type: none"> ○ MSA-110 Masilla Juntas Blanco Roto - Bote 1,8 Kg ● PTX-95-400 Pintura Juntas Arena Acabado Liso <p>+Complementos opcionales para la instalación / Optional materials for installation</p> <ul style="list-style-type: none"> ○ MSA-3-280 Masilla de Pegado 	<p>Rendimiento Aproximado / Average Usage</p> <p>1 Bote cada 8/10 paneles 1 Bote cada 8 paneles</p> <p>1 Bote cada 4 paneles</p>
  <p>Ref.5 CAMEL CAMEL</p>	<p>Complementos necesarios para la instalación / Necessary materials for installation</p> <ul style="list-style-type: none"> ○ MSA-110 Masilla Juntas Blanco Roto - Bote 1,8 Kg ● PTX-96-400 Pintura Juntas Camel Acabado Liso <p>+Complementos opcionales para la instalación / Optional materials for installation</p> <ul style="list-style-type: none"> ○ MSA-3-280 Masilla de Pegado 	<p>Rendimiento Aproximado / Average Usage</p> <p>1 Bote cada 8/10 paneles 1 Bote cada 8 paneles</p> <p>1 Bote cada 4 paneles</p>

  <p>Ref. 16 TABACO TOBACCO</p>	<p>Complementos necesarios para la instalación / Necessary materials for installation</p> <ul style="list-style-type: none"> ○ MSA-110 Masilla Juntas Blanco Roto - Bote 1,8 Kg ● PTX-102-400 Pintura Juntas Tabaco Acabado Liso <p>+Complementos opcionales para la instalación / Optional materials for installation</p> <ul style="list-style-type: none"> ○ MSA-3-280 Masilla de Pegado 	<p>Rendimiento Aproximado / Average Usage</p> <p>1 Bote cada 8/10 paneles 1 Bote cada 8 paneles</p> <p>1 Bote cada 4 paneles</p>
  <p>Ref. 6 PLOMO LEAD</p>	<p>Complementos necesarios para la instalación / Necessary materials for installation</p> <ul style="list-style-type: none"> ○ MSA-110 Masilla Juntas Blanco Roto - Bote 1,8 Kg ● PTX-97-400 Pintura Juntas Plomo Acabado Liso <p>+Complementos opcionales para la instalación / Optional materials for installation</p> <ul style="list-style-type: none"> ○ MSA-3-280 Masilla de Pegado 	<p>Rendimiento Aproximado / Average Usage</p> <p>1 Bote cada 8/10 paneles 1 Bote cada 8 paneles</p> <p>1 Bote cada 4 paneles</p>
  <p>Ref. 7 GRIS GREY</p>	<p>Complementos necesarios para la instalación / Necessary materials for installation</p> <ul style="list-style-type: none"> ○ MSA-110 Masilla Juntas Blanco Roto - Bote 1,8 Kg ● PTX-98-400 Pintura Juntas Gris Acabado Liso <p>+Complementos opcionales para la instalación / Optional materials for installation</p> <ul style="list-style-type: none"> ○ MSA-3-280 Masilla de Pegado 	<p>Rendimiento Aproximado / Average Usage</p> <p>1 Bote cada 8/10 paneles 1 Bote cada 8 paneles</p> <p>1 Bote cada 4 paneles</p>
  <p>Ref. 8 MARENGO MARENGO</p>	<p>Complementos necesarios para la instalación / Necessary materials for installation</p> <ul style="list-style-type: none"> ○ MSA-110 Masilla Juntas Blanco Roto - Bote 1,8 Kg ● PTX-99-400 Pintura Juntas Marengo Acabado Liso <p>+Complementos opcionales para la instalación / Optional materials for installation</p> <ul style="list-style-type: none"> ○ MSA-3-280 Masilla de Pegado 	<p>Rendimiento Aproximado / Average Usage</p> <p>1 Bote cada 8/10 paneles 1 Bote cada 8 paneles</p> <p>1 Bote cada 4 paneles</p>
  <p>Ref. 9 NEGRO BLACK</p>	<p>Complementos necesarios para la instalación / Necessary materials for installation</p> <ul style="list-style-type: none"> ○ MSA-110 Masilla Juntas Blanco Roto - Bote 1,8 Kg ● PTX-100-400 Pintura Juntas Negro Acabado Liso <p>+Complementos opcionales para la instalación / Optional materials for installation</p> <ul style="list-style-type: none"> ○ MSA-3-280 Masilla de Pegado 	<p>Rendimiento Aproximado / Average Usage</p> <p>1 Bote cada 8/10 paneles 1 Bote cada 8 paneles</p> <p>1 Bote cada 4 paneles</p>
   <p>IMITACIÓN CEMENTO IMITATION CONCRETE</p>	<p>Complementos necesarios para la instalación / Necessary materials for installation</p> <ul style="list-style-type: none"> ○ MSA-10 Masilla Juntas Beige Pizarra ● PTX-64-400 Pintura Juntas Cemento <p>+Complementos opcionales para la instalación / Optional materials for installation</p> <ul style="list-style-type: none"> ○ MSA-3-280 Masilla de Pegado 	<p>Rendimiento Aproximado / Average Usage</p> <p>1 Bote cada 3 paneles 1 Bote cada 8 paneles</p> <p>1 Bote cada 4 paneles</p>

SLIM



SLIM

Crea espacios arquitectónicos, modernos y minimalistas, que despuntarán por su gran sencillez y belleza.

It creates modern, minimalist architectural spaces that stand out for their simplicity and beauty.

ECO
LUXER

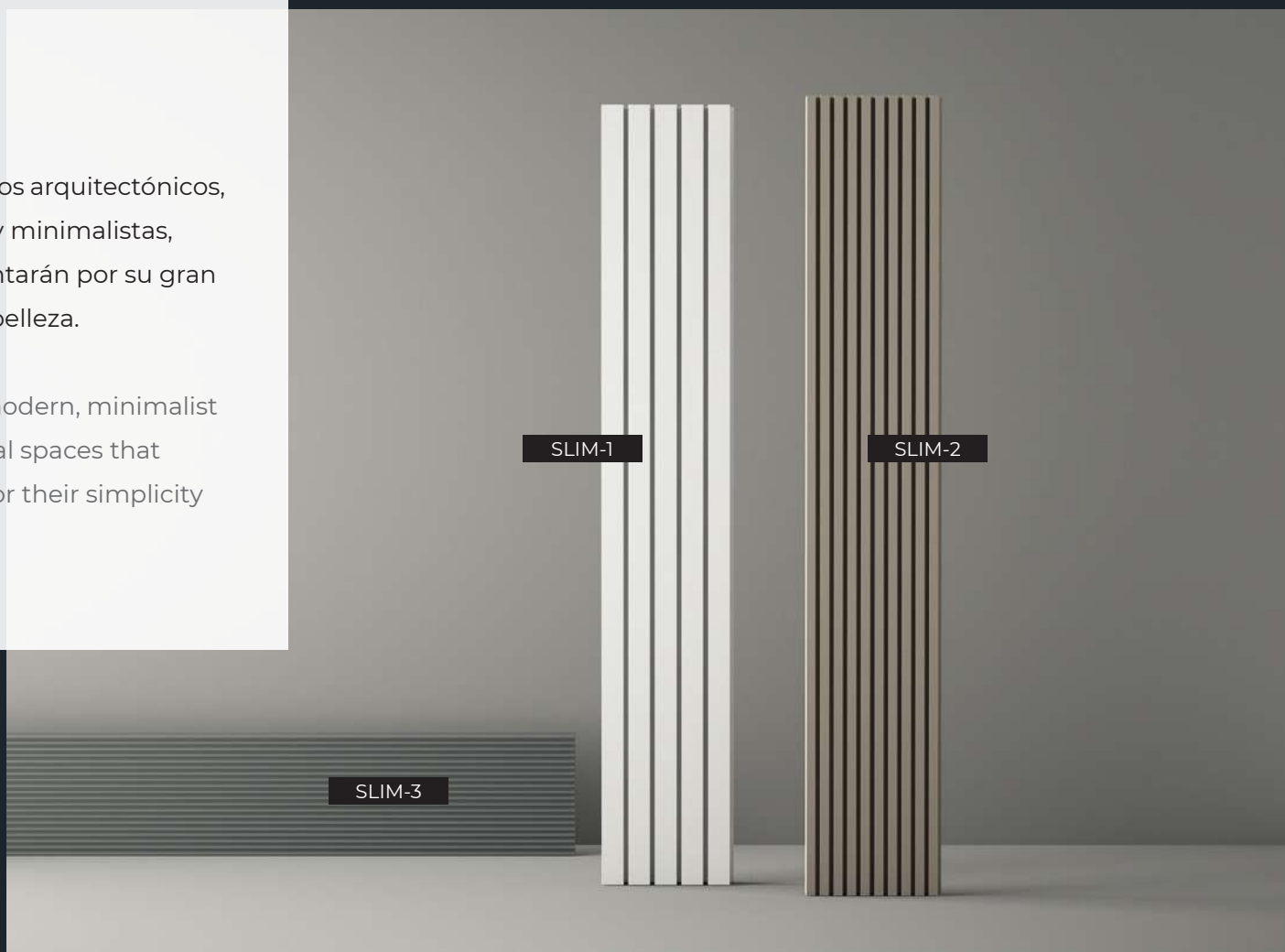

museum

SLIM-2 LX-721 MARENCO
SLIM-1 LX-720 CREMA
SLIM-3 LX-722 CREMA
PERFIL L LX-PLL CREMA

Versatilidad
Versatility

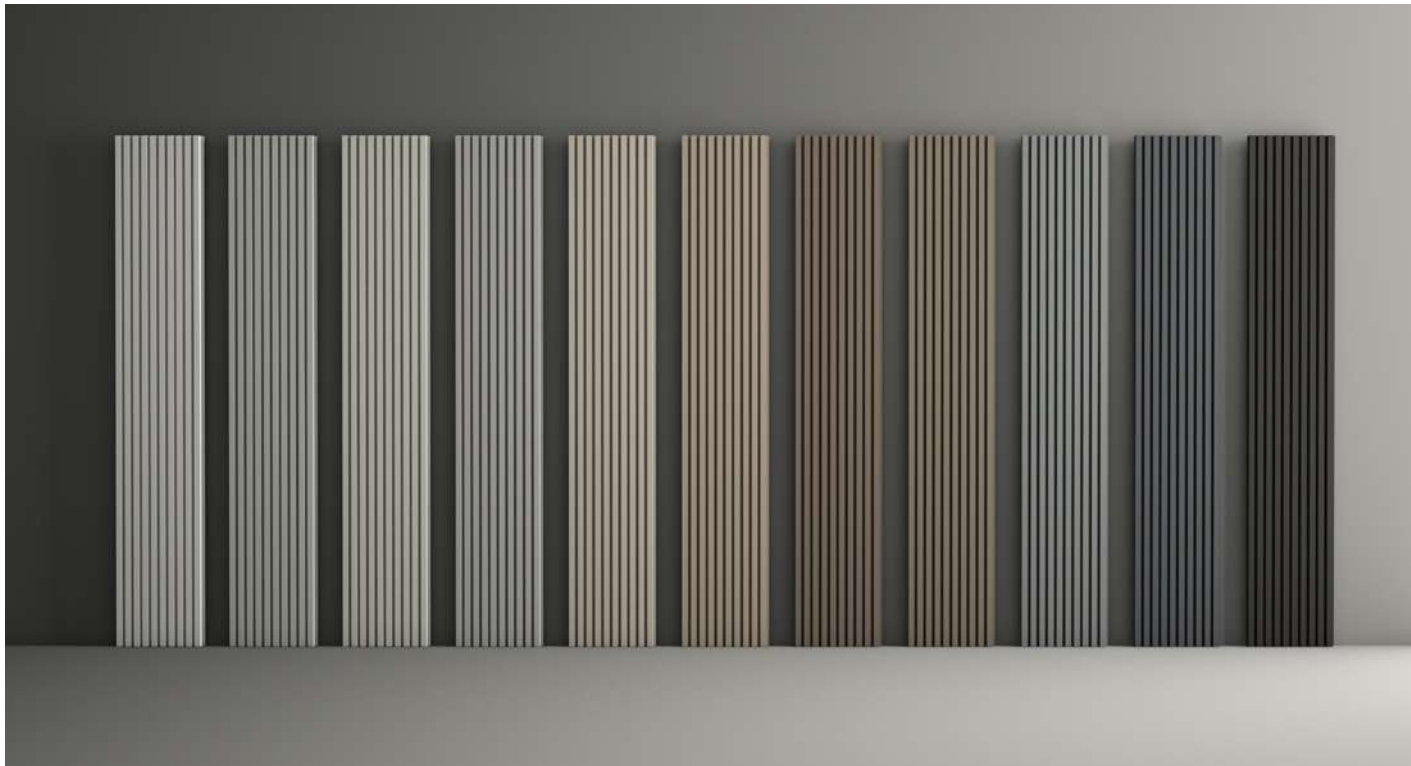



SLIM-2 LX-721 CAMEL
SLIM-3 LX-722 CAMEL



SLIM-2 LX-721 BLANCO





SLIM-2 LX-721 BLANCO

SLIM-1 LX-720 CREMA
PERFIL L LX-PLL CREMA
SLIM-1 LX-721 CREMA



Arquitek SLIM

Medidas en cm. / Measures in cm.

Las medidas pueden variar +/- 1cm / Measurements may vary +/- 1cm

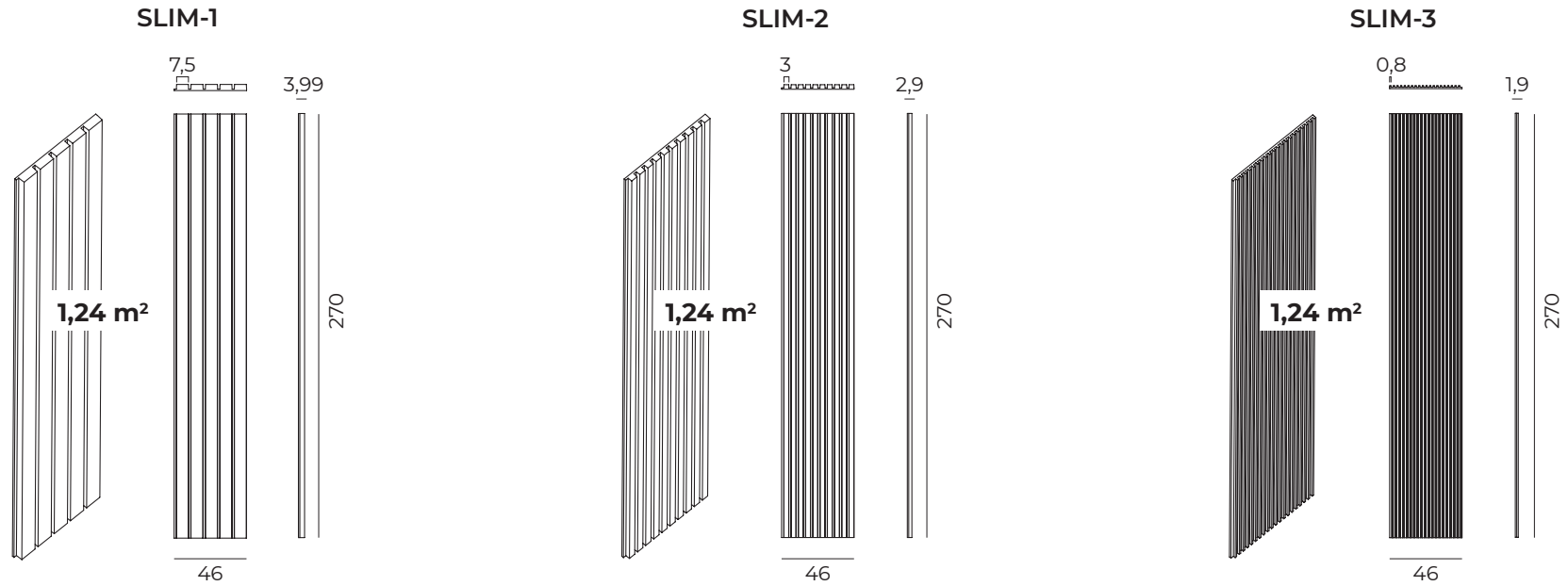

*SE PUEDEN COMBINAR CON NUESTROS PERFILES / *CAN BE COMBINED WITH OUR PROFILES

Acabado de Colores / Finished Colours

- | | | | |
|-----------------------------|--------------------------------|--------------------------------|---------------------------------|
| 1
BLANCO
WHITE | 15
HUESO
BONE | 2
CREMA
CREAM | 3
CEMENTO
CONCRETE |
| 4
ARENA
SAND | 5
CAMEL
CAMEL | 16
TABACO
TOBACCO | 6
PLOMO
LEAD |
| 7
GRIS
GREY | 8
MARENGO
MARENGO | 9
NEGRO
BLACK | |

*Ver especificaciones de acabados: página 16-17 /
*See finish specifications: page 16-17



CALIDADES / QUALITIES	REFERENCIA / CODE	DESCRIPCIÓN / DESCRIPTION	KG.
	LX-720	Panel SLIM-1	LX: 13/15 Kg
	LX-721	Panel SLIM-2	LX: 13 Kg
	LX-722	Panel SLIM-3	LX: 11/12 Kg

Kg. pueden variar +/- / Kg. may vary +/-

MILO



MILO

Tres tamaños de grosor para un panel lineal y estructural, con un acabado de cemento muy realista.

Three thickness sizes for a linear, structural panel with a realistic cement finish.

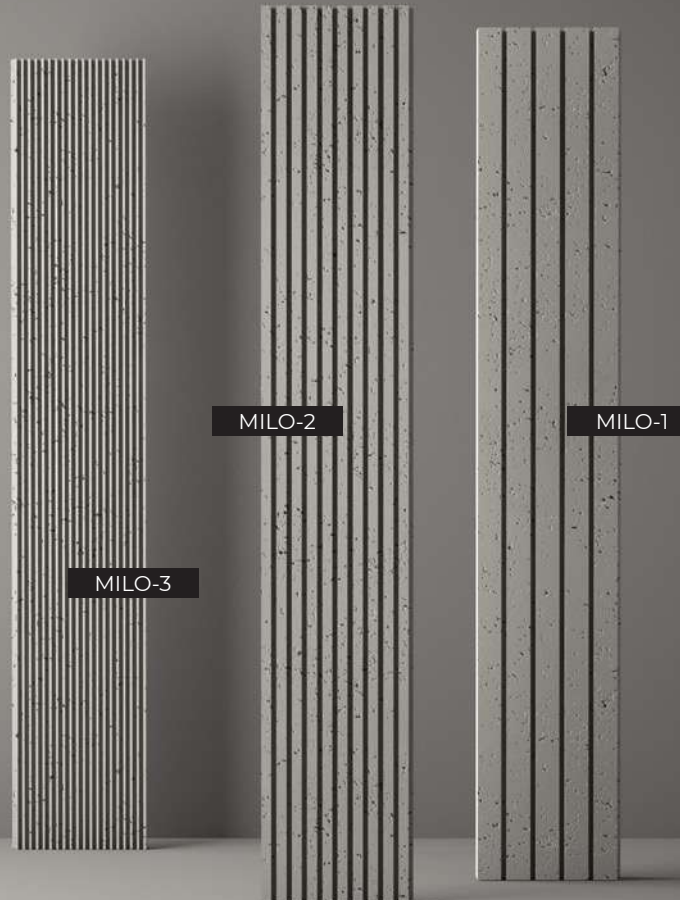

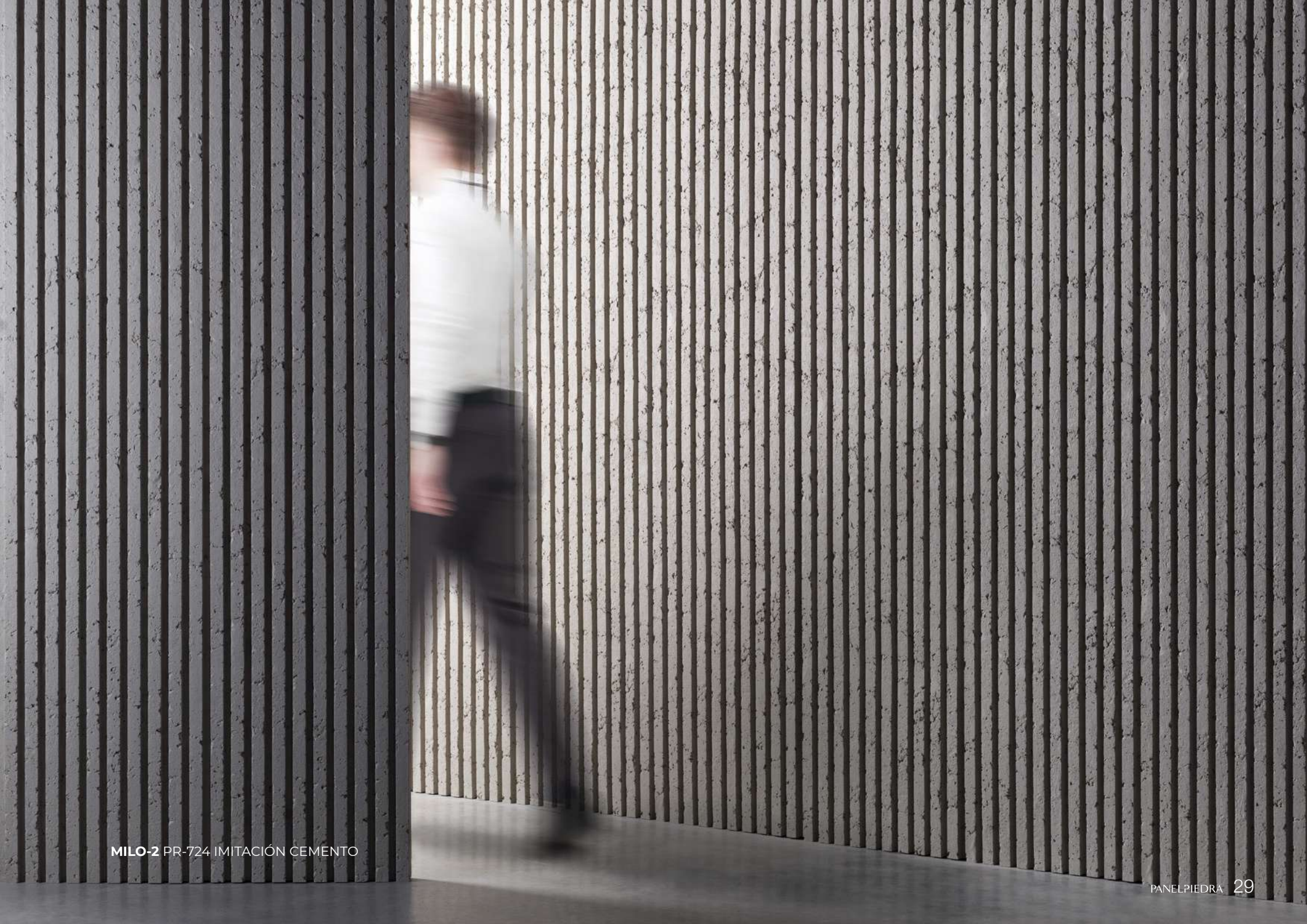

MILO-2 PR-724 IMITACIÓN CEMENTO

MILO-2 PR-724 IMITACIÓN CEMENTO

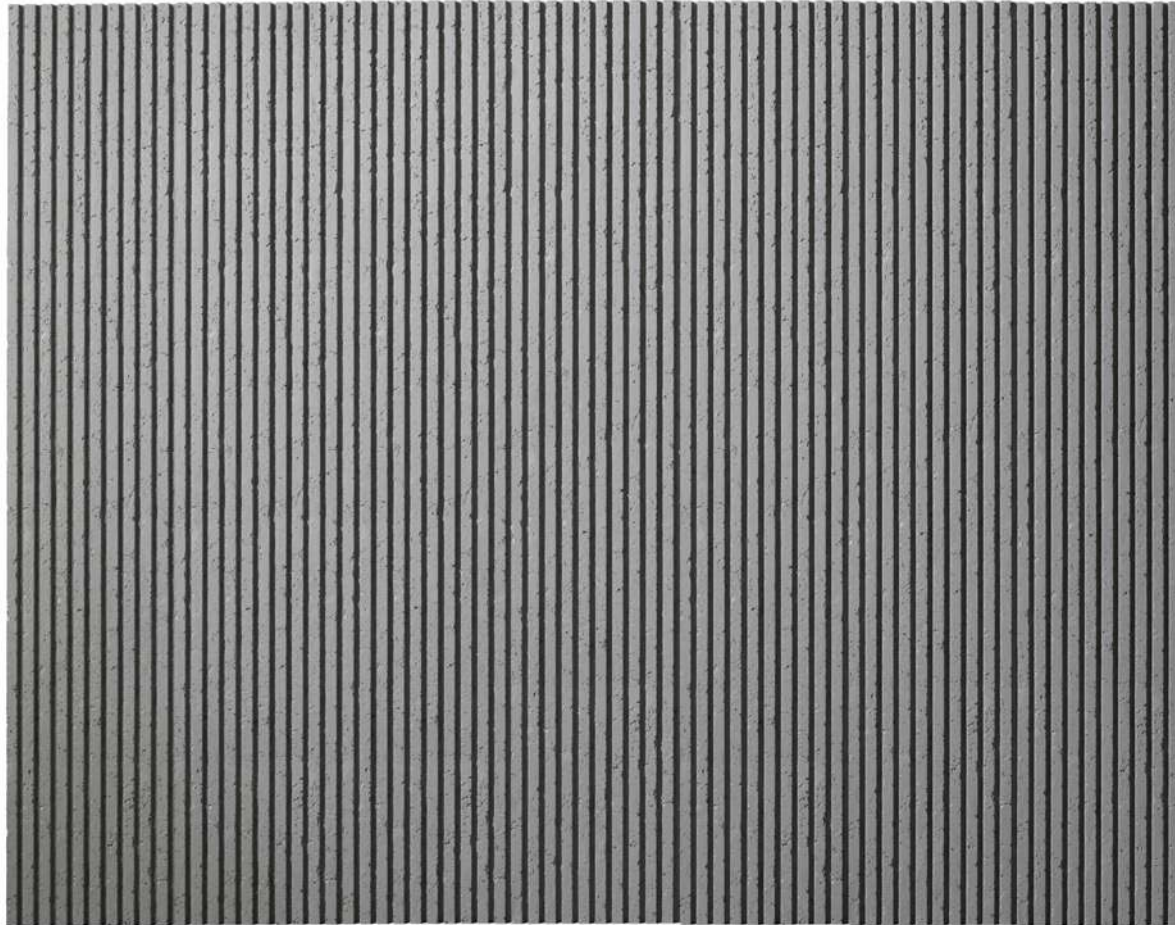



MILO-2 PR-724 IMITACIÓN CEMENTO

Arquitek MILO

Medidas en cm. / Measures in cm.

Las medidas pueden variar +/-1cm. / Measurements may vary +/-1cm

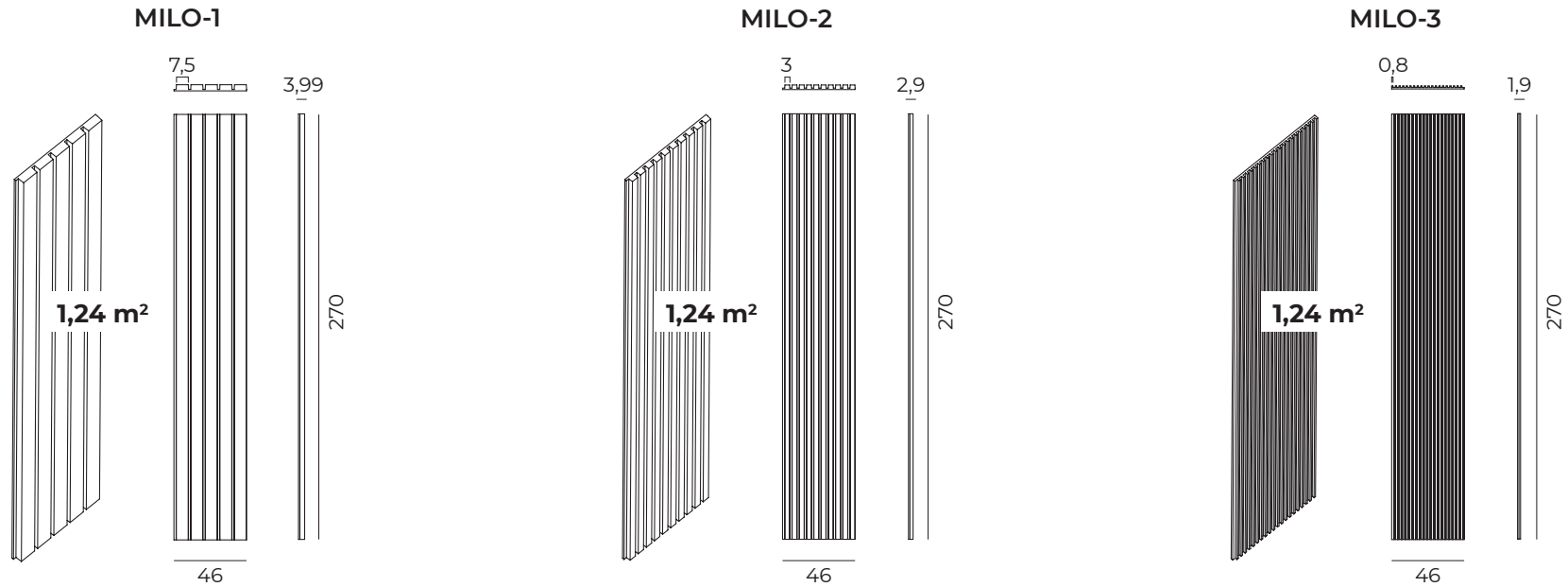

*SE PUEDEN COMBINAR CON NUESTROS PERFILES / *CAN BE COMBINED WITH OUR PROFILES

Acabado de Colores / Finished Colours



*Ver especificaciones de acabados: página 16-17 /
*See finish specifications: page 16-17

CALIDADES / QUALITIES	REFERENCIA / CODE	DESCRIPCIÓN / DESCRIPTION	KG.
	PR-723	Panel MILO-1	PR: 10 Kg
	PR-724	Panel MILO-2	PR: 9 Kg
	PR-725	Panel MILO-3	PR: 9 Kg
	LX-723	Panel MILO-1	PR: 13/15 Kg
	LX-724	Panel MILO-2	PR: 13 Kg
	LX-725	Panel MILO-3	PR: 11/12 Kg

Kg. pueden variar +/- / Kg. may vary +/-

ICON



ICON

Modelo original y de gran belleza, por su versatilidad a la hora de componer en una pared.

An original model of great beauty, due to its versatility when it comes to composing a wall.

ECO
LUXER

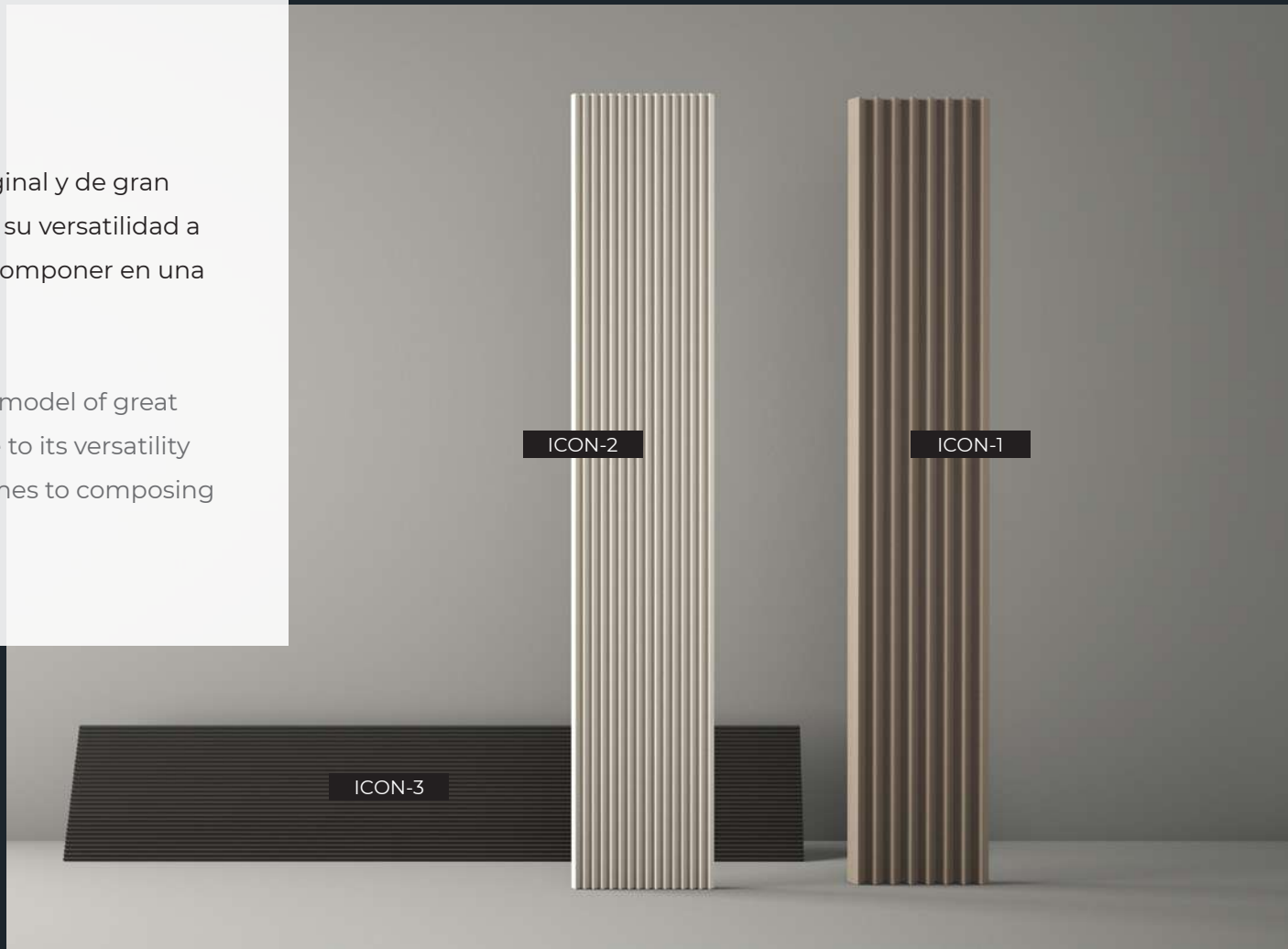



ICON-2 LX-727 BLANCO



ICON-3 LX-728 PLOMO
PERFIL L LX-PLL PLOMO
ICON-1 LX-726 PLOMO
PERFIL M LX-PML PLOMO

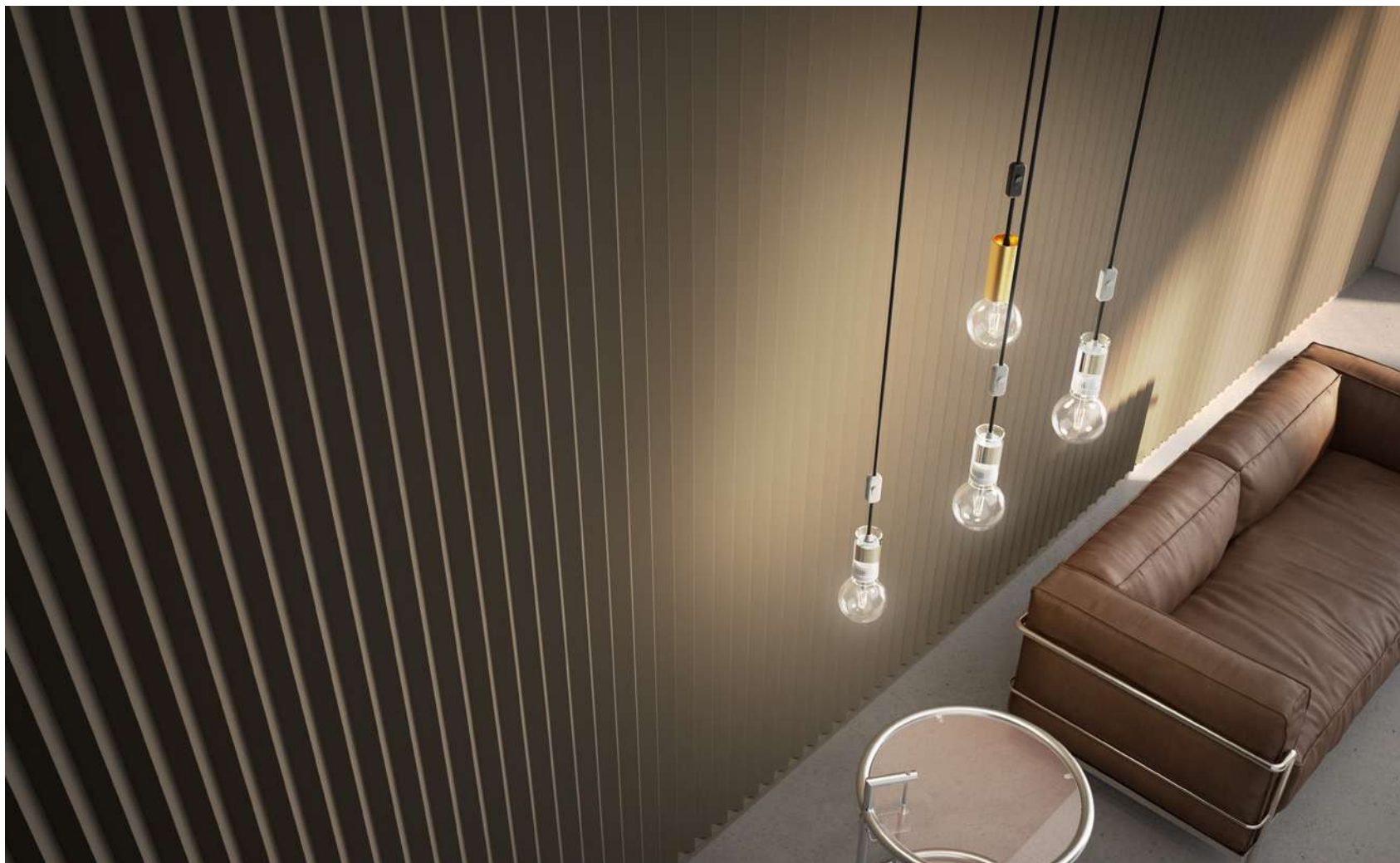

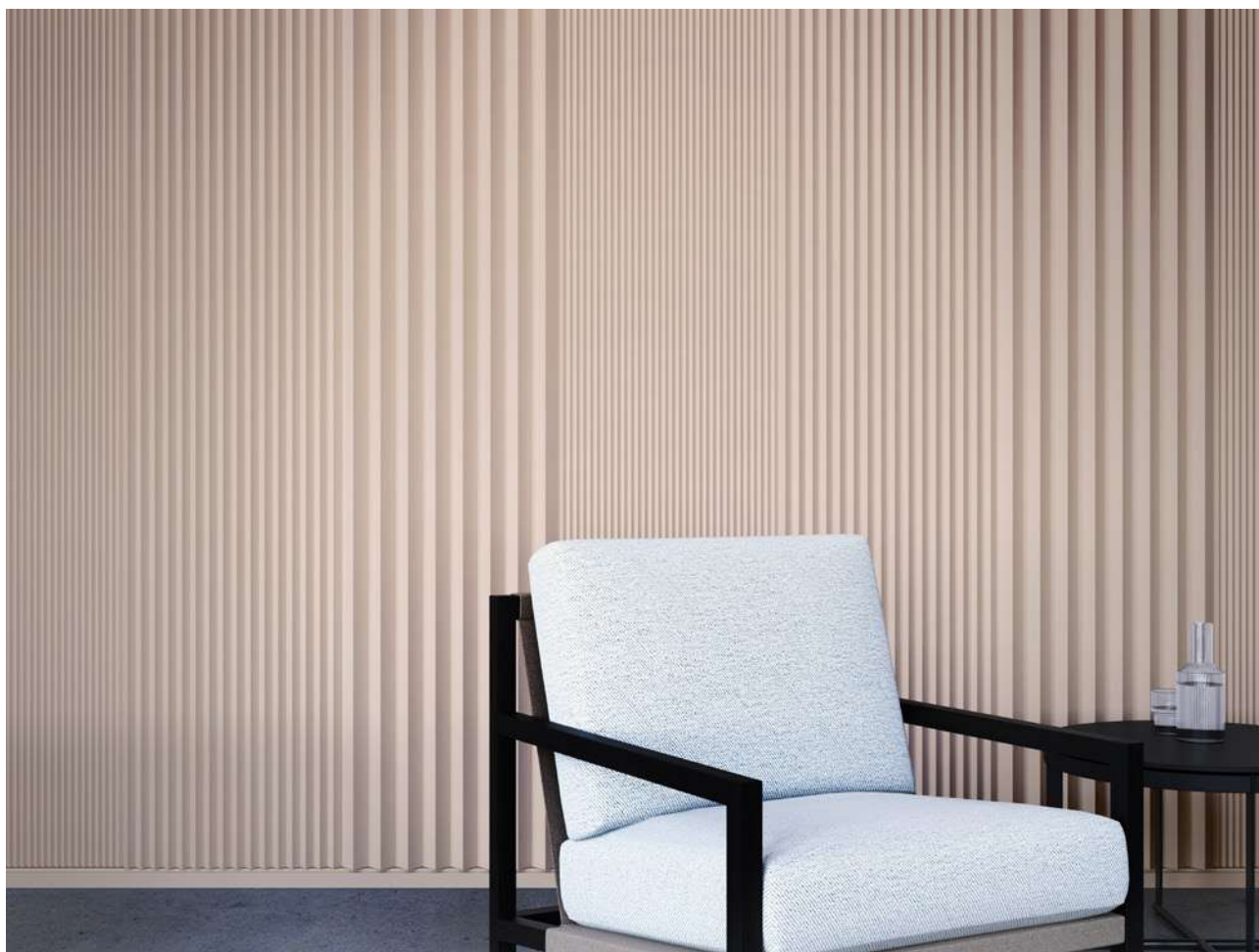

ICON-1 LX-726 CREMA
ICON-2 LX-727 CREMA
ICON-3 LX-728 CREMA
PERFIL L LX-PLL CREMA
PERFIL M LX-PML CREMA



ICON-2 LX-727 BLANCO
PERFIL M LX-PML BLANCO



Arquitek ICON

Medidas en cm. / Measures in cm.

Las medidas pueden variar +/-1cm / Measurements may vary +/-1cm

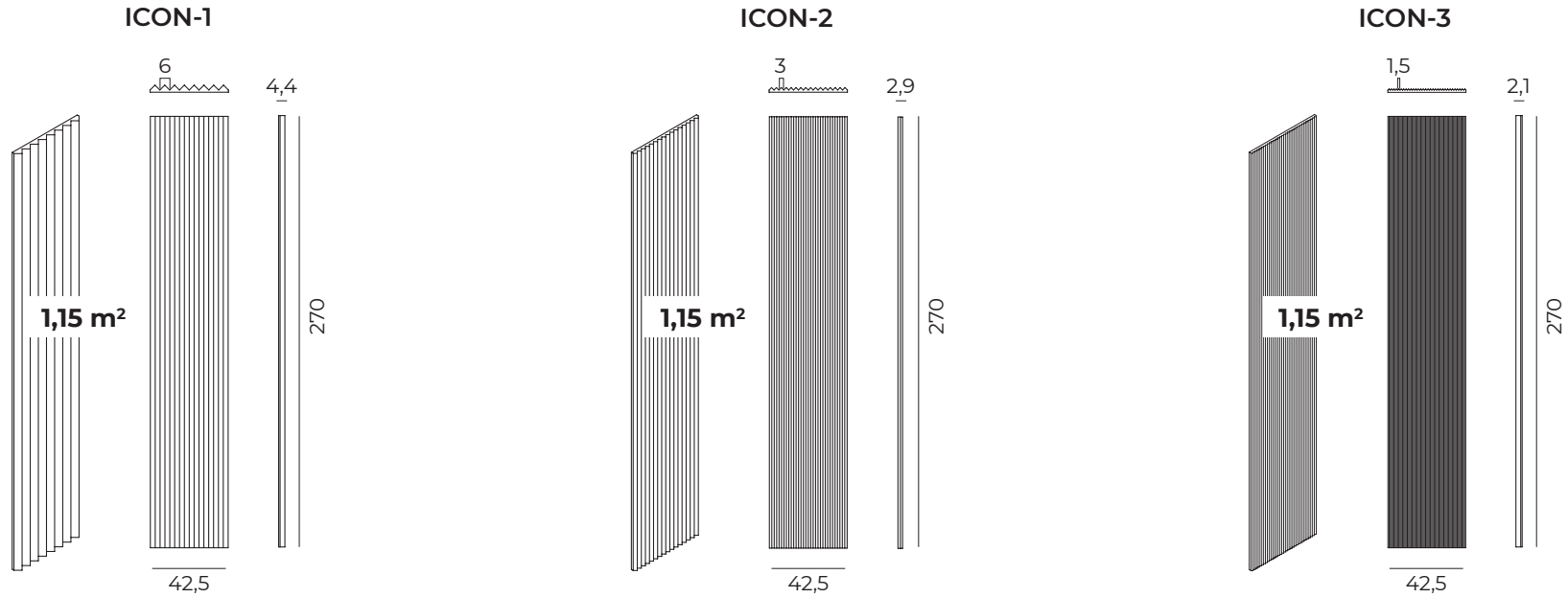

*SE PUEDEN COMBINAR CON NUESTROS PERFILES / *CAN BE COMBINED WITH OUR PROFILES

Acabado de Colores / Finished Colours



*Ver especificaciones de acabados: página 16-17 /
*See finish specifications: page 16-17



CALIDADES / QUALITIES	REFERENCIA / CODE	DESCRIPCIÓN / DESCRIPTION	KG.
	LX-726	Panel ICON-1	LX: 13/15 Kg
	LX-727	Panel ICON-2	LX: 12/13 Kg
	LX-728	Panel ICON-3	LX: 11/12 Kg

Kg. pueden variar +/- / Kg. may vary +/-

SPIRIT



SPIRIT

Modelo similar a Icon pero con imitación cemento.
Elegancia en acabado de gran realismo.

Model similar to Icon but with cement imitation, elegance in a very realistic finish.





SPIRIT-1 PR-729 IMITACIÓN CEMENTO
SPIRIT-1 LX-729 IMITACIÓN CEMENTO (Exterior)



SPRIT-3 PR-731 IMITACIÓN CEMENTO
PERFIL L LX-PLL BLANCO
SPRIT-2 PR-730 IMITACIÓN CEMENTO



SPIRIT-1 LX-729 IMITACIÓN CEMENTO (Exterior)
PERFIL L PR-PLC



Arquitek SPIRIT

Medidas en cm. / Measures in cm.

Las medidas pueden variar +/-1cm / Measurements may vary +/-1cm

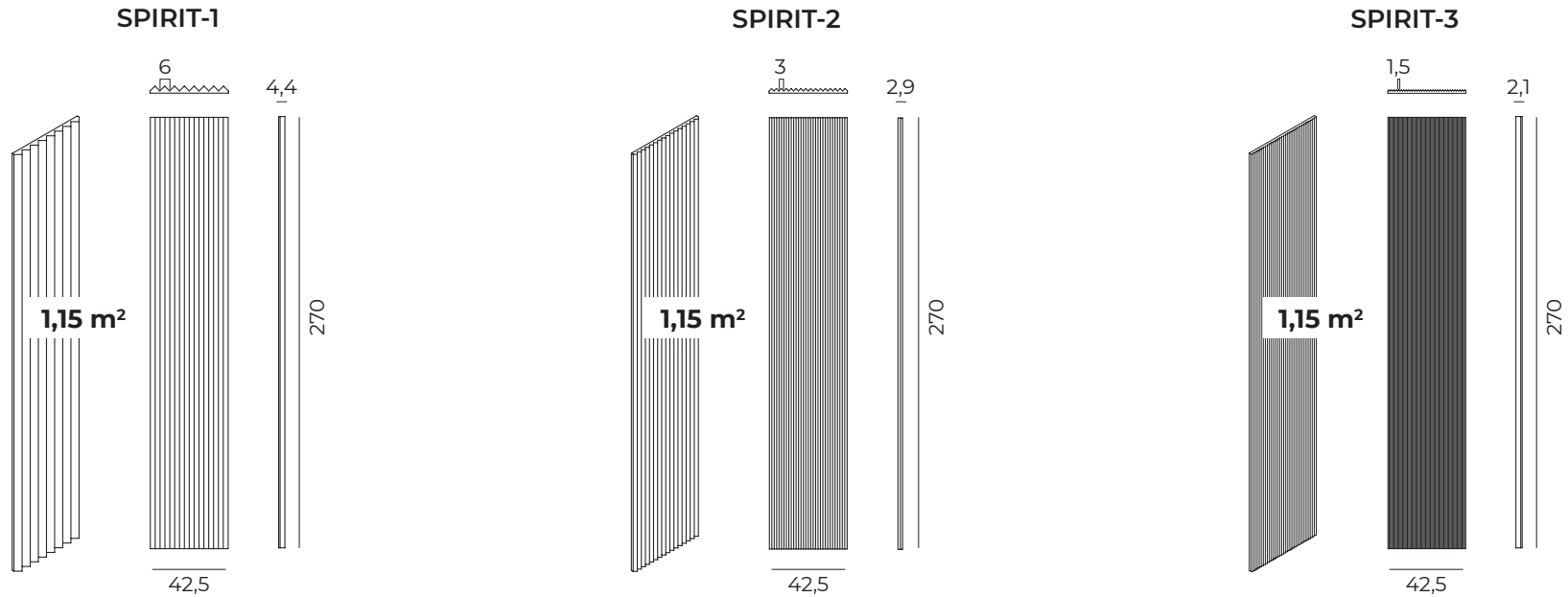

*SE PUEDEN COMBINAR CON NUESTROS PERFILES / *CAN BE COMBINED WITH OUR PROFILES

Acabado de Colores / Finished Colours



IMITACIÓN CEMENTO
IMITATION CONCRETE

*Ver especificaciones de acabados: página 16-17 /
*See finish specifications: page 16-17



PR

PR-729
PR-730
PR-731

Panel SPIRIT-1
Panel SPIRIT-2
Panel SPIRIT-3

KG.
PR: 10 Kg
PR: 9 Kg
PR: 9 Kg



ECO
LUXER

LX-729
LX-730
LX-731

Panel SPIRIT-1
Panel SPIRIT-2
Panel SPIRIT-3

LX: 13/15 Kg
LX: 12/13 Kg
LX: 11/12 Kg

Kg. pueden variar +/- / Kg. may vary +/-

ARKO



ARKO

Modelo pensado para crear espacios arquitectónicos espectaculares, por su fácil combinación y composición entre sus cuatro tamaños.

Model designed to create spectacular architectural spaces, due to its easy combination and composition between its four sizes.

ECO
LUXER

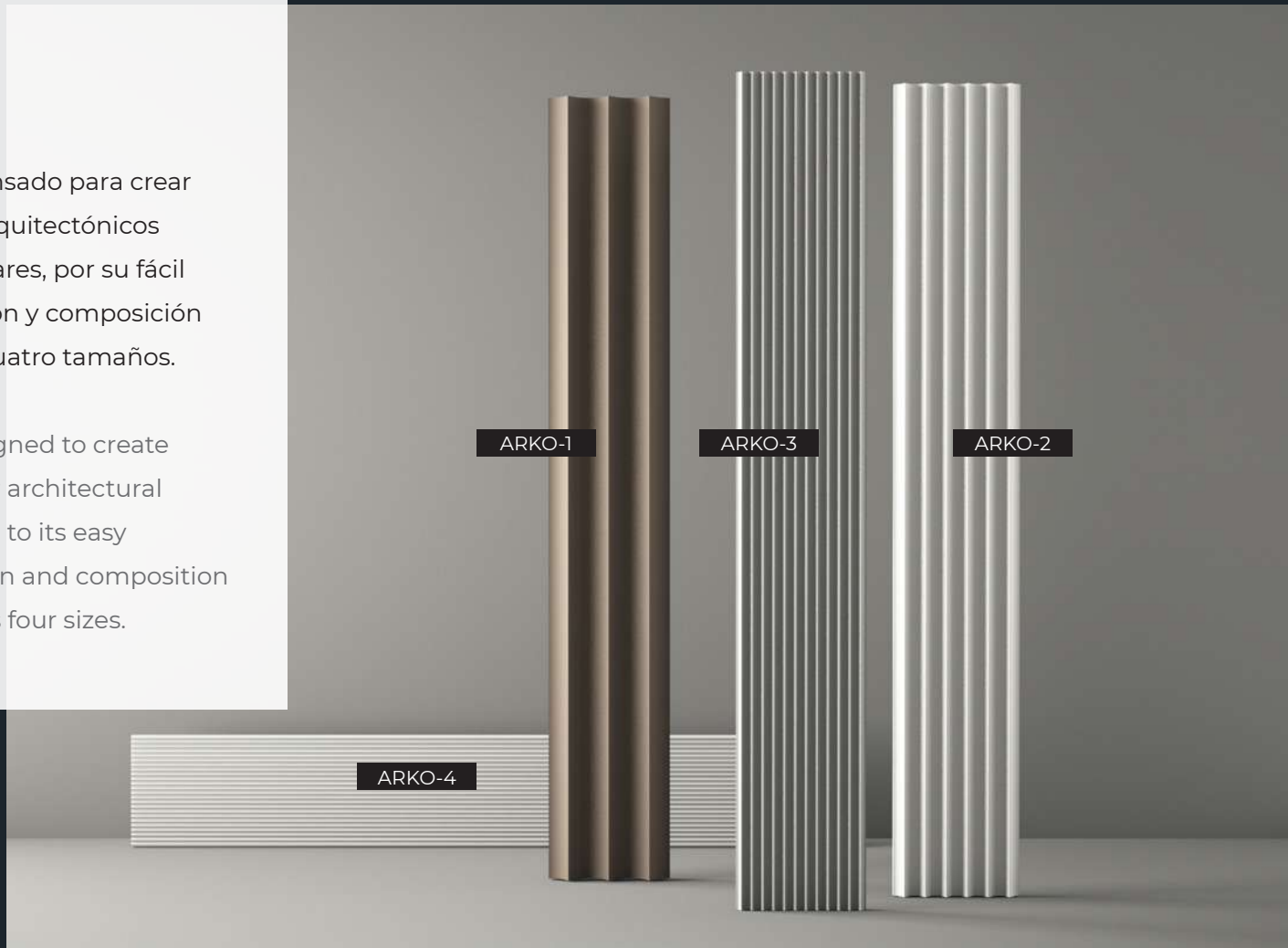



ARKO-1 LX-732 ARENA
PERFIL L LX-PLL ARENA
ARKO-3 LX-734 CAMEL

ARKO-1 LX-732 ARENA
PERFIL L LX-PLL ARENA
ARKO-3 LX-734 CAMEL



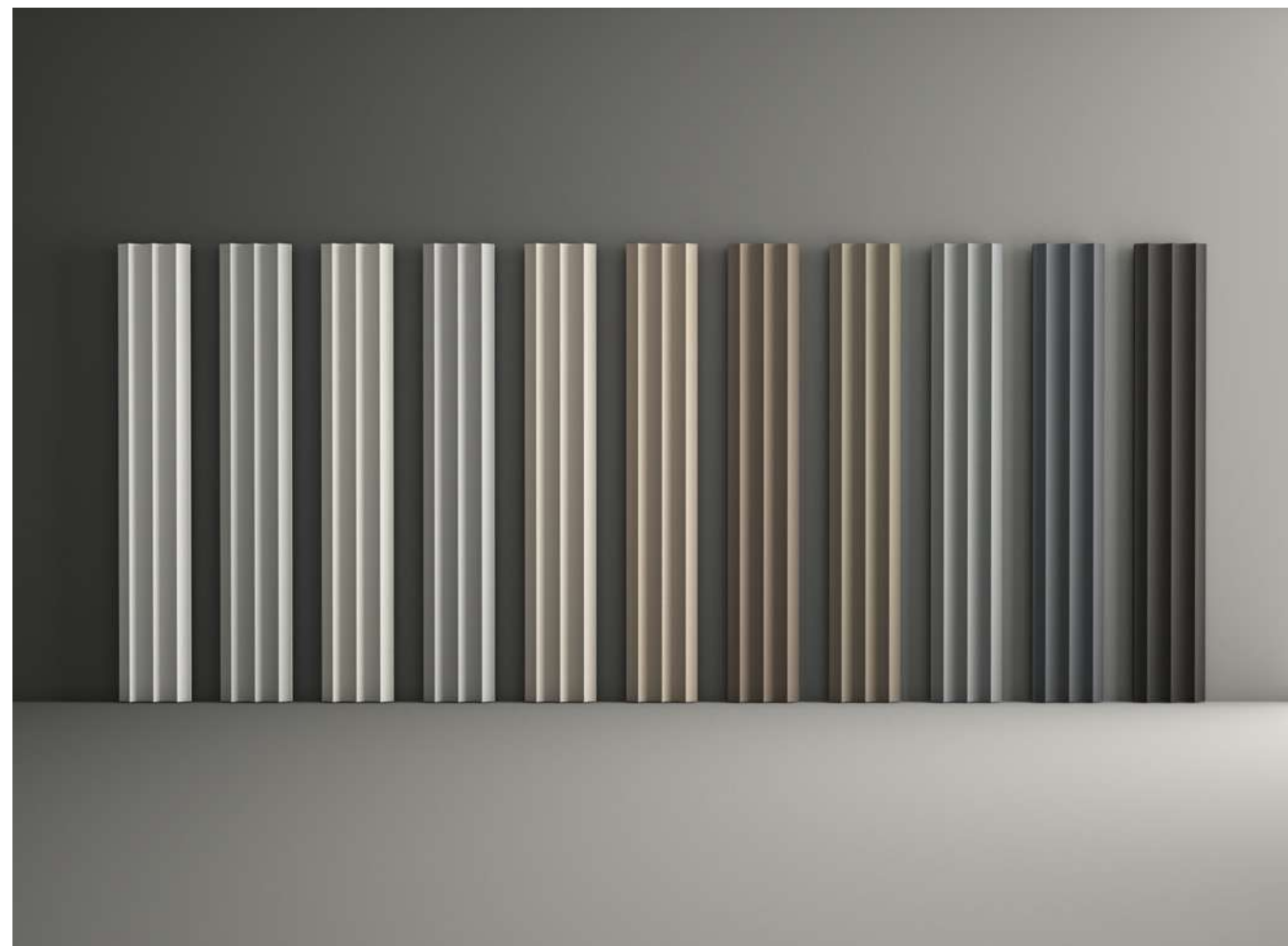



ARKO-2 LX-733 HUESO
ARKO-1 LX-732 MARENGO

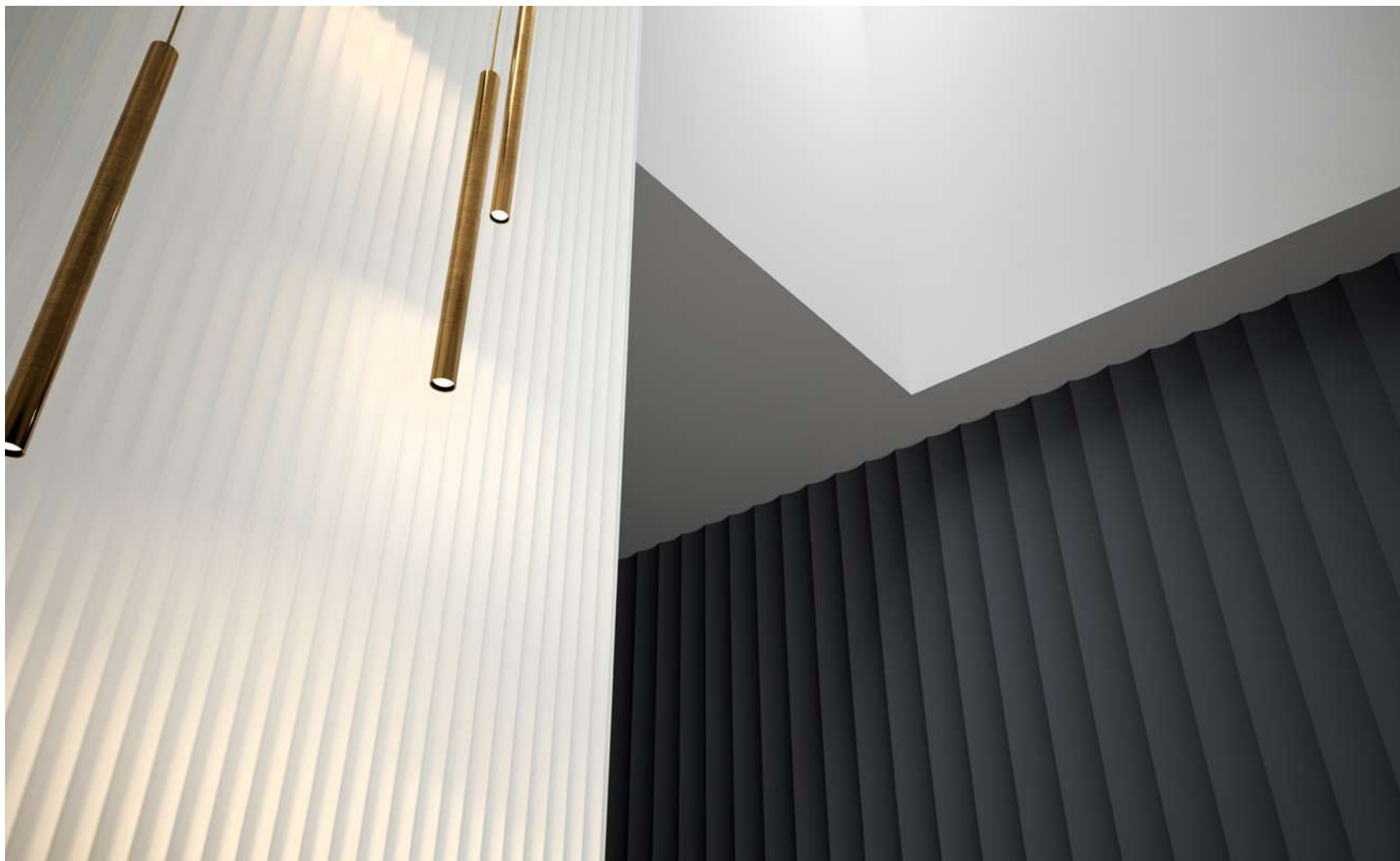



Infinitas
combinaciones
Infinite combinations

Arquitek ARKO

Medidas en cm. / Measures in cm.

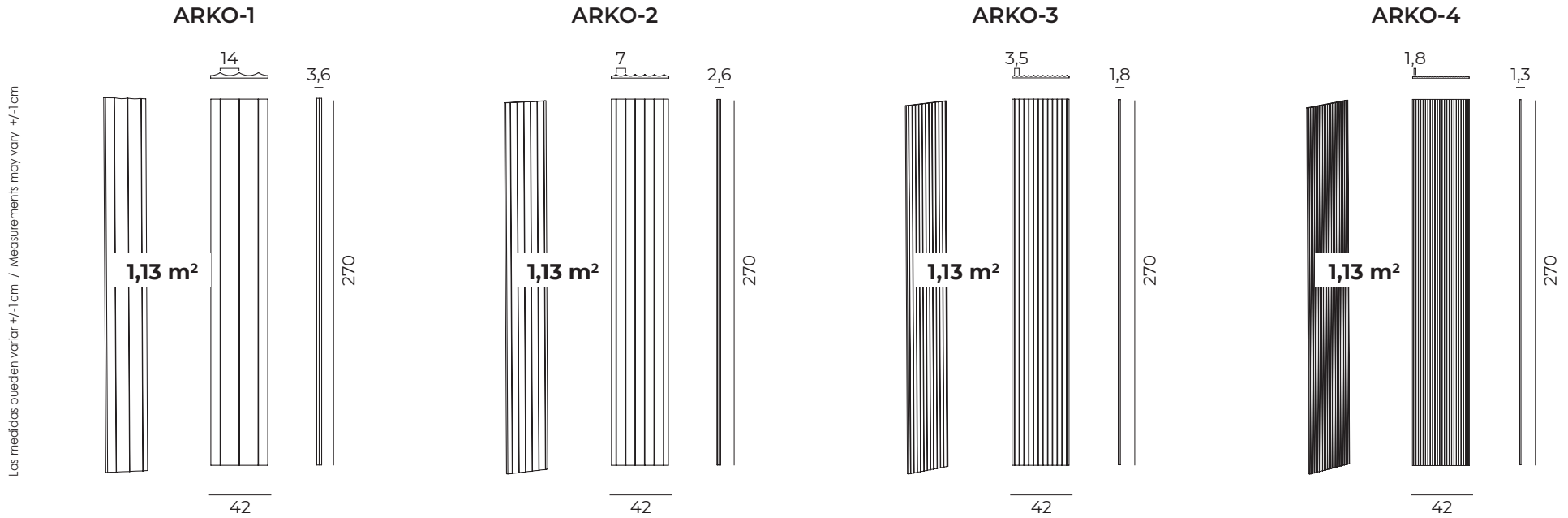

*SE PUEDEN COMBINAR CON NUESTROS PERFILES / *CAN BE COMBINED WITH OUR PROFILES

Acabado de Colores / Finished Colours

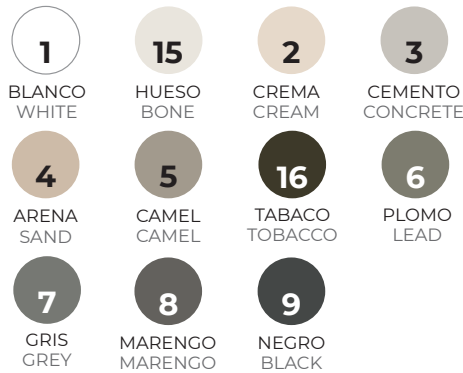

*Ver especificaciones de acabados: página 16-17 /
*See finish specifications: page 16-17



CALIDADES / QUALITIES	REFERENCIA / CODE	DESCRIPCIÓN / DESCRIPTION	KG.
	LX-732	Panel ARKO-1	LX: 15 Kg
	LX-733	Panel ARKO-2	LX: 13/14 Kg
	LX-734	Panel ARKO-3	LX: 12/13 Kg
	LX-735	Panel ARKO-4	LX: 11/12 Kg

Kg. pueden variar +/- / Kg. may vary +/-

ALMA



ALMA

Igual de espectacular que el modelo Arko pero con acabado cemento de gran realismo.

Just as spectacular as the Arko model but with a very realistic ceme



ALMA-4



ALMA-3



ALMA-1



ALMA-2





ALMA-1 PR-736 IMITACIÓN CEMENTO
HORMIGÓN PR-326 GRIS (Cement Collection)

ALMA-3 PR-738 IMITACIÓN CEMENTO
ALMA-1 PR-736 IMITACIÓN CEMENTO
PERFIL M LX-PML GRIS







Combinable with other collections
Combinables
con otras colecciones

ALMA-1 PR-736 IMITACIÓN CEMENTO
HORMIGÓN PR-326 GRIS (Cement Collection)

Arquitek ALMA

Medidas en cm. / Measures in cm.

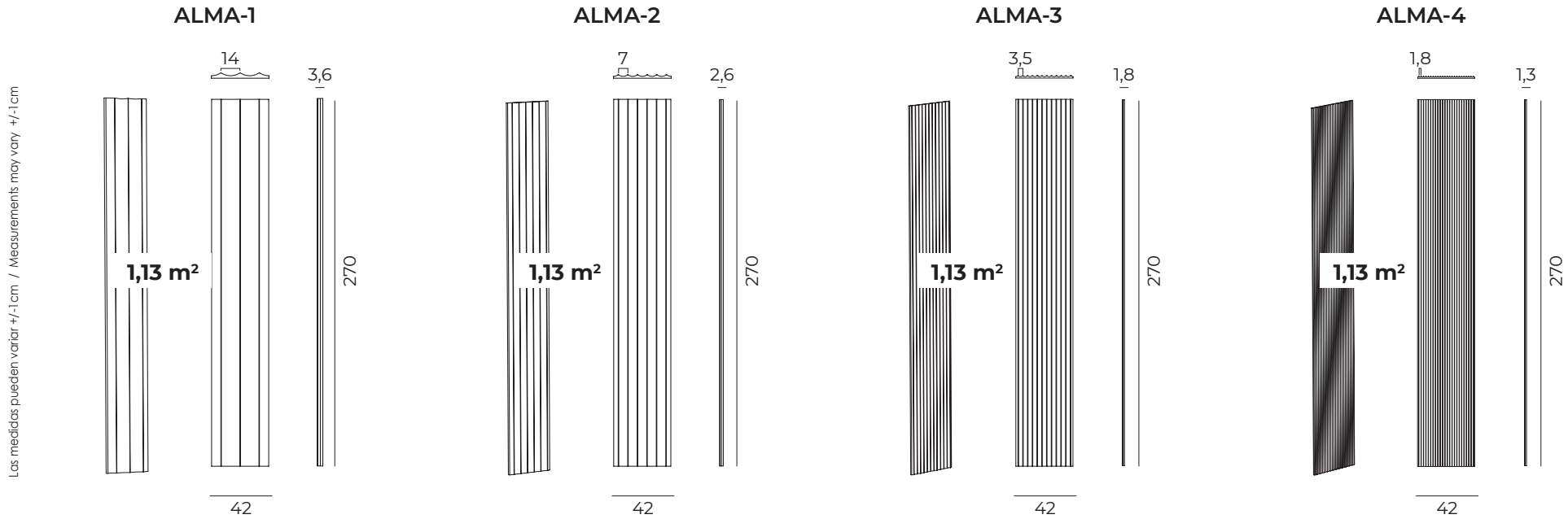

*SE PUEDEN COMBINAR CON NUESTROS PERFILES / *CAN BE COMBINED WITH OUR PROFILES

Acabado de Colores / Finished Colours



IMITACIÓN CEMENTO
IMITATION CONCRETE

*Ver especificaciones de acabados: página 16-17 /
*See finish specifications: page 16-17



CALIDADES / QUALITIES	REFERENCIA / CODE	DESCRIPCIÓN / DESCRIPTION	KG.
PR	PR-736	Panel ALMA-1	PR: 11 Kg
	PR-737	Panel ALMA-2	PR: 10 Kg
	PR-738	Panel ALMA-3	PR: 9 Kg
	PR-739	Panel ALMA-4	PR: 9 Kg
ECO LUXER	LX-736	Panel ALMA-1	LX: 15 Kg
	LX-737	Panel ALMA-2	LX: 13/14 Kg
	LX-738	Panel ALMA-3	LX: 12/13 Kg
	LX-739	Panel ALMA-4	PR: 11/12 Kg

Kg. pueden variar +/- / Kg. may vary +/-

MODUS



MODUS

Unos de nuestros paneles mas elegantes es, sin duda, el modelo Modus. En cualquier color, es simplemente bello.

One of our most elegant panels is undoubtedly the Modus model. In any colour, it is simply beautiful.

ECO
LUXER





MODUS LX-747 CAMEL

MODUS LX-747 CAMEL



MODUS LX-747 NEGRO





MODUS LX-747 BLANCO



Belleza

Beauty



Arquitek MODUS

Medidas en cm. / Measures in cm.

Las medidas pueden variar +/-1cm / Measurements may vary +/-1cm

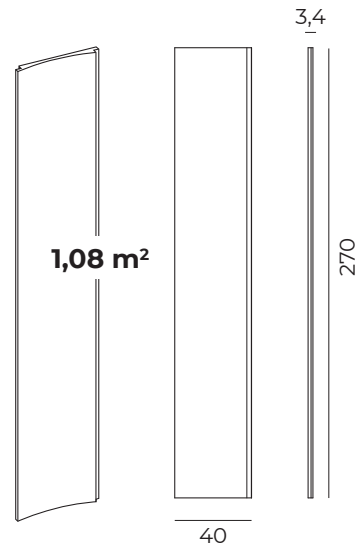



*SE PUEDEN COMBINAR CON NUESTROS PERFILES / *CAN BE COMBINED WITH OUR PROFILES

Acabado de Colores / Finished Colours



*Ver especificaciones de acabados: página 16-17 /
*See finish specifications: page 16-17

CALIDADES / QUALITIES	REFERENCIA / CODE	DESCRIPCIÓN / DESCRIPTION	KG.
 	LX-747	Panel MODUS	LX: 13 Kg

Kg. pueden variar +/- / Kg. may vary +/-

NEOS



NEOS

Unos de los modelos más elegante junto con Modus. Con un acabado cemento, simplemente espectacular.

One of the most elegant models together with Modus. With a cement finish, simply spectacular.



NEOS

PR

ECO
LUXER



NEOS PR-740 IMITACIÓN CEMENTO

NEOS PR-740 IMITACIÓN CEMENTO





NEOS PR-740 IMITACIÓN CEMENTO



Arquitek NEOS

Medidas en cm. / Measures in cm.

Las medidas pueden variar +/-1cm / Measurements may vary +/-1cm

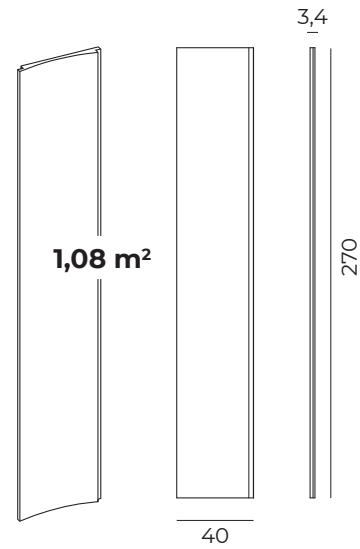

*SE PUEDEN COMBINAR CON NUESTROS PERFILES / *CAN BE COMBINED WITH OUR PROFILES

Acabado de Colores / Finished Colours



IMITACIÓN CEMENTO
IMITATION CONCRETE

*Ver especificaciones de acabados: página 16-17 /
*See finish specifications: page 16-17

CALIDADES / QUALITIES	REFERENCIA / CODE	DESCRIPCIÓN / DESCRIPTION	KG.
 INTERIOR INDOOR		PR-740	Panel NEOS PR: 10 Kg
 EXTERIOR E INTERIOR OUTSIDE & INDOOR		LX-740	Panel NEOS PR: 13 Kg

Kg. pueden variar +/- / Kg. may vary +/-

SCALON



SCALON

Por sus formas originales y lineales hacen que este panel sea uno de los más bellos y modernos.

Its original and linear shapes make this panel one of the most beautiful and modern.

ECO
LUXER





SCALON-1 LX-741 GRIS
SCALON-1 LX-741 HUESO

SCALON-1 LX-741 GRIS
PERFIL L LX-PLL GRIS
SCALON-1 LX-741 HUESO
SCALON-1 LX-741 MARENGO
PERFIL L LX-PLL MARENGO



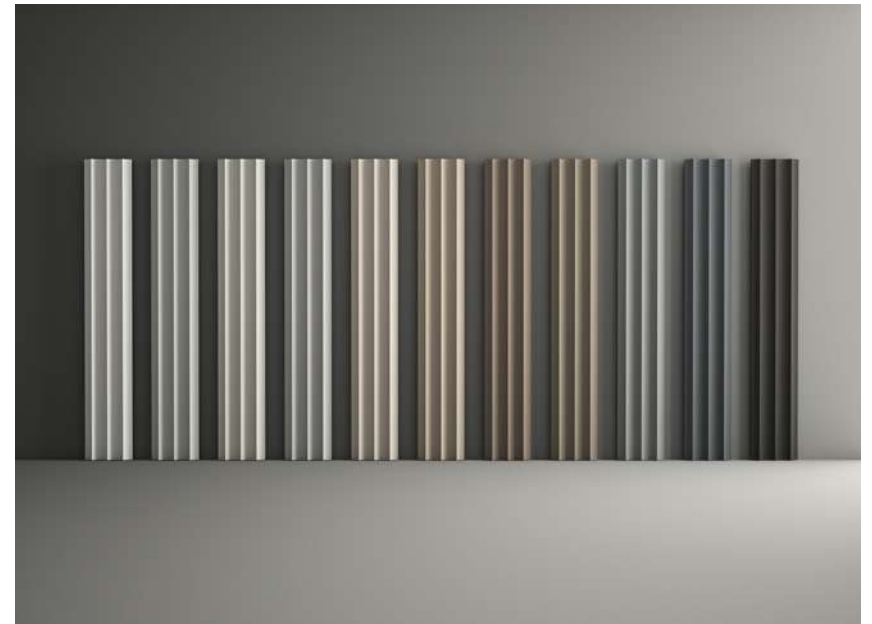

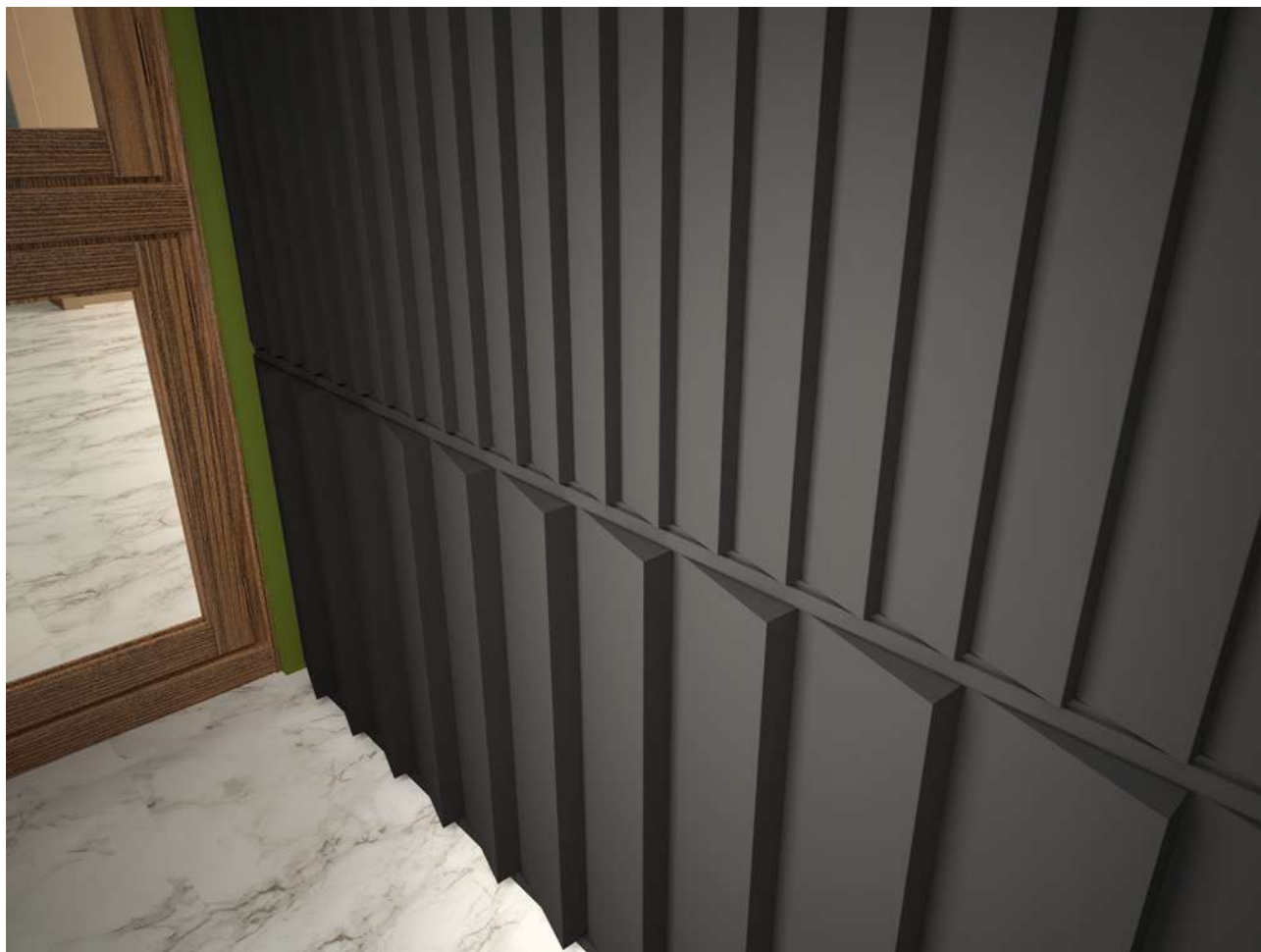

SCALON 2 LX-742 MARENGO

PERFIL L LX-PLL MARENGO

SCALON 1 LX-741 MARENGO



hab: 501-508

Variedad de
posibilidades
Variety of possibilities



Arquitek SCALON

Medidas en cm. / Measures in cm.

Las medidas pueden variar +/-1cm / Measurements may vary +/-1cm

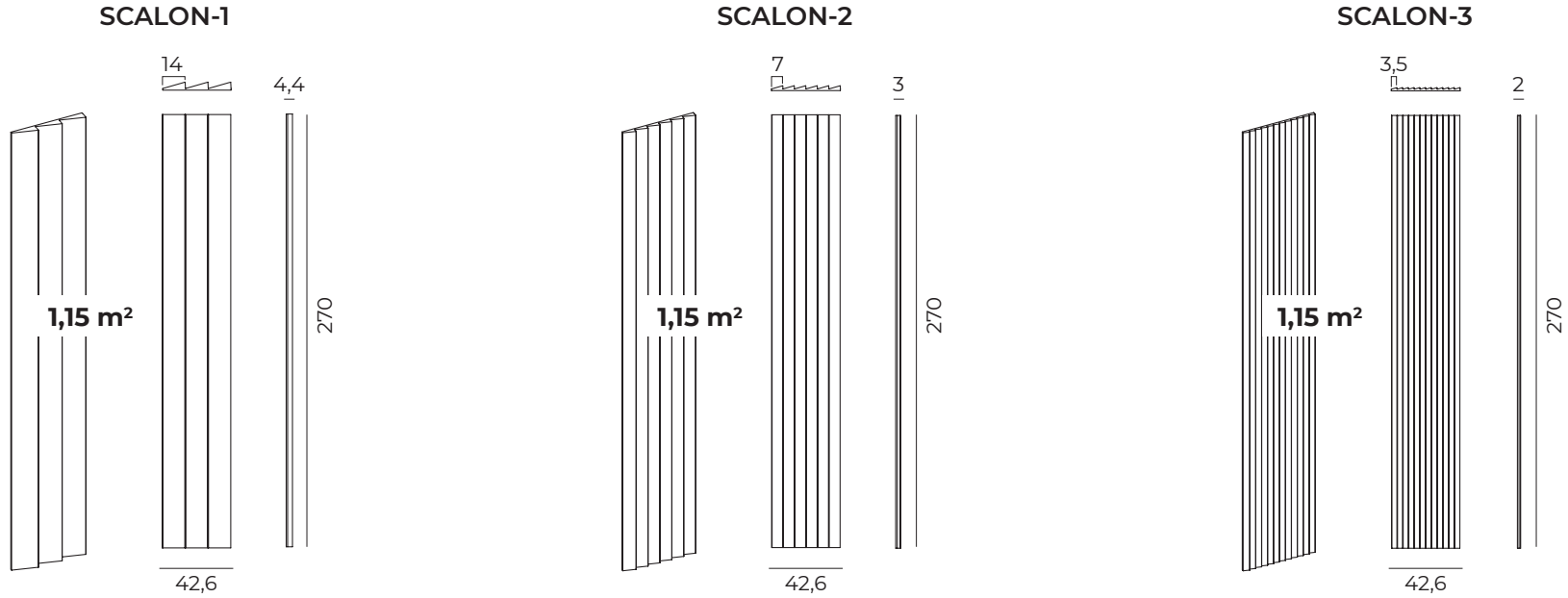

*SE PUEDEN COMBINAR CON NUESTROS PERFILES / *CAN BE COMBINED WITH OUR PROFILES

Acabado de Colores / Finished Colours

- | | | | |
|-----------------------------|--------------------------------|--------------------------------|---------------------------------|
| 1
BLANCO
WHITE | 15
HUESO
BONE | 2
CREMA
CREAM | 3
CEMENTO
CONCRETE |
| 4
ARENA
SAND | 5
CAMEL
CAMEL | 16
TABACO
TOBACCO | 6
PLOMO
LEAD |
| 7
GRIS
GREY | 8
MARENCO
MARENCO | 9
NEGRO
BLACK | |

*Ver especificaciones de acabados: página 16-17 /
*See finish specifications: page 16-17



CALIDADES / QUALITIES	REFERENCIA / CODE	DESCRIPCIÓN / DESCRIPTION	KG.
	LX-741	Panel SCALON-1	LX: 13/15 Kg
	LX-742	Panel SCALON-2	LX: 12/13 Kg
	LX-743	Panel SCALON-3	LX: 11/12 Kg

Kg. pueden variar +/- / Kg. may vary +/-

LOUN



LOUN

Paneles en tres grosores de original diseño con una acabado de cemento perfectamente conseguido.

Panels in three thicknesses of original design with a perfectly achieved cement finish.



PR

ECO
LUXER



LOUN-2 PR-745 IMITACIÓN CEMENTO







LOUN-1 PR-744 IMITACIÓN CEMENTO
LOUN-3 PR-746 IMITACIÓN CEMENTO
LOUN-2 PR-745 IMITACIÓN CEMENTO





Arquitek LOUN

Medidas en cm. / Measures in cm.

Las medidas pueden variar +/-1cm / Measurements may vary +/-1cm

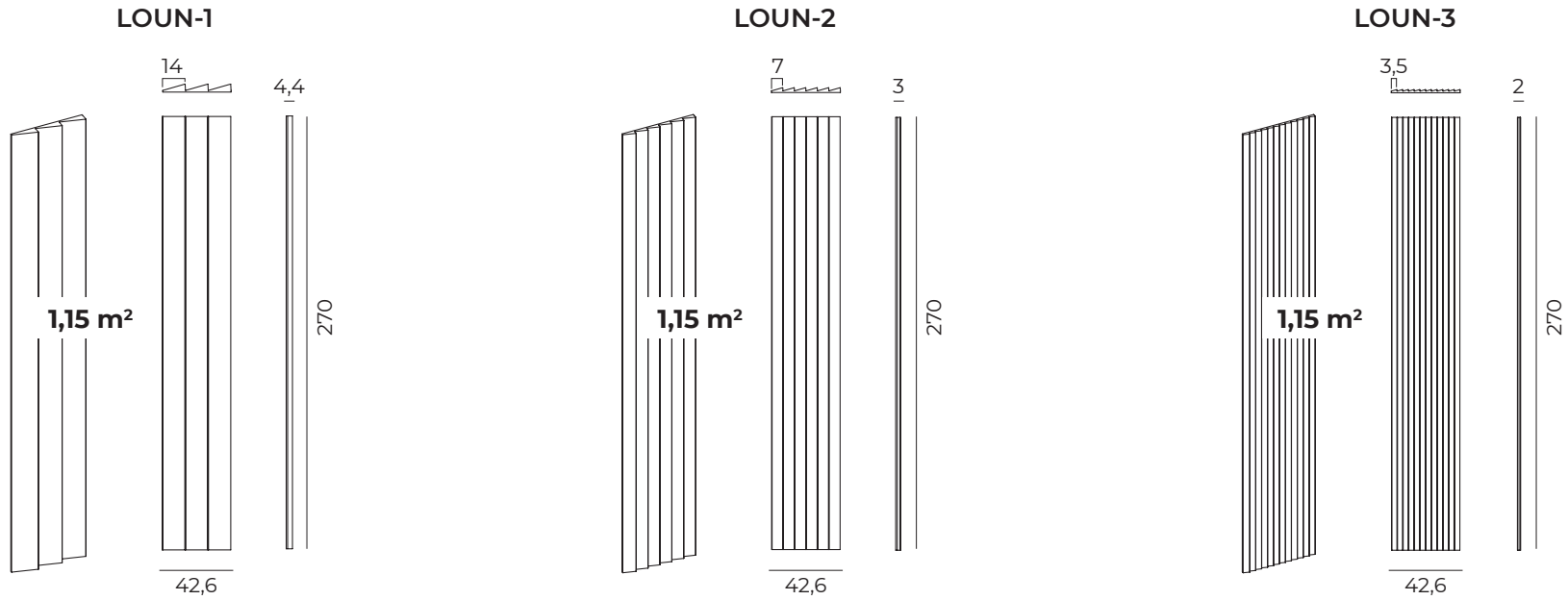

*SE PUEDEN COMBINAR CON NUESTROS PERFILES / *CAN BE COMBINED WITH OUR PROFILES

Acabado de Colores / Finished Colours



IMITACIÓN CEMENTO
IMITATION CONCRETE

*Ver especificaciones de acabados: página 16-17 /
*See finish specifications: page 16-17



PR

PR-744

PR-745

PR-746



ECO
LUXER

LX-744

LX-745

LX-746

DESCRIPCIÓN
DESCRIPTION

KG.

Panel LOUN-1

Panel LOUN-2

Panel LOUN-3

Panel LOUN-1

Panel LOUN-2

Panel LOUN-3

PR: 10 Kg

PR: 9 Kg

PR: 9 Kg

LX: 13/15 Kg

LX: 12/13 Kg

LX: 11/12 Kg

Kg. pueden variar +/- / Kg. may vary +/-

INNER



INNER

Panel en un solo tamaño, con un diseño original y creativo hará de cualquier estancia un espacio diferente.

Panel in one size, with an original and creative design will make any room a different space.

ECO
LUXER

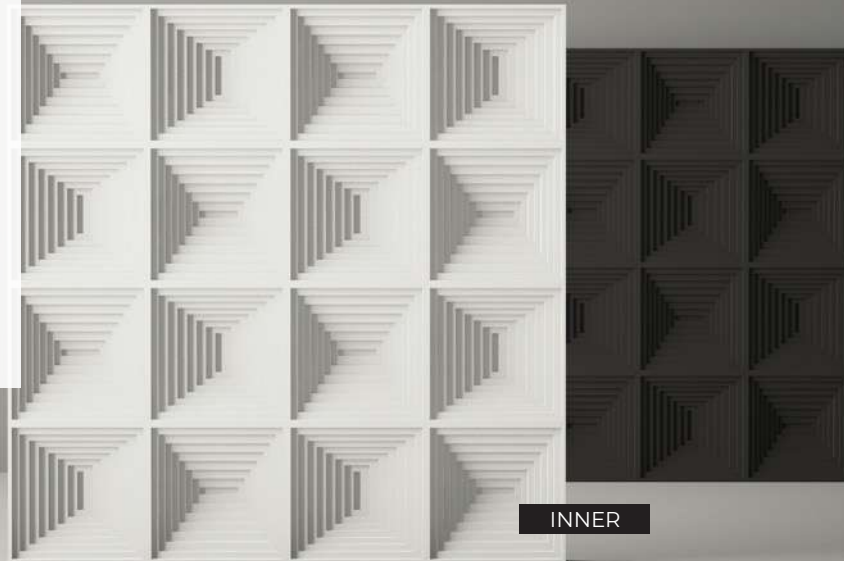

INNER LX-748 BLANCO



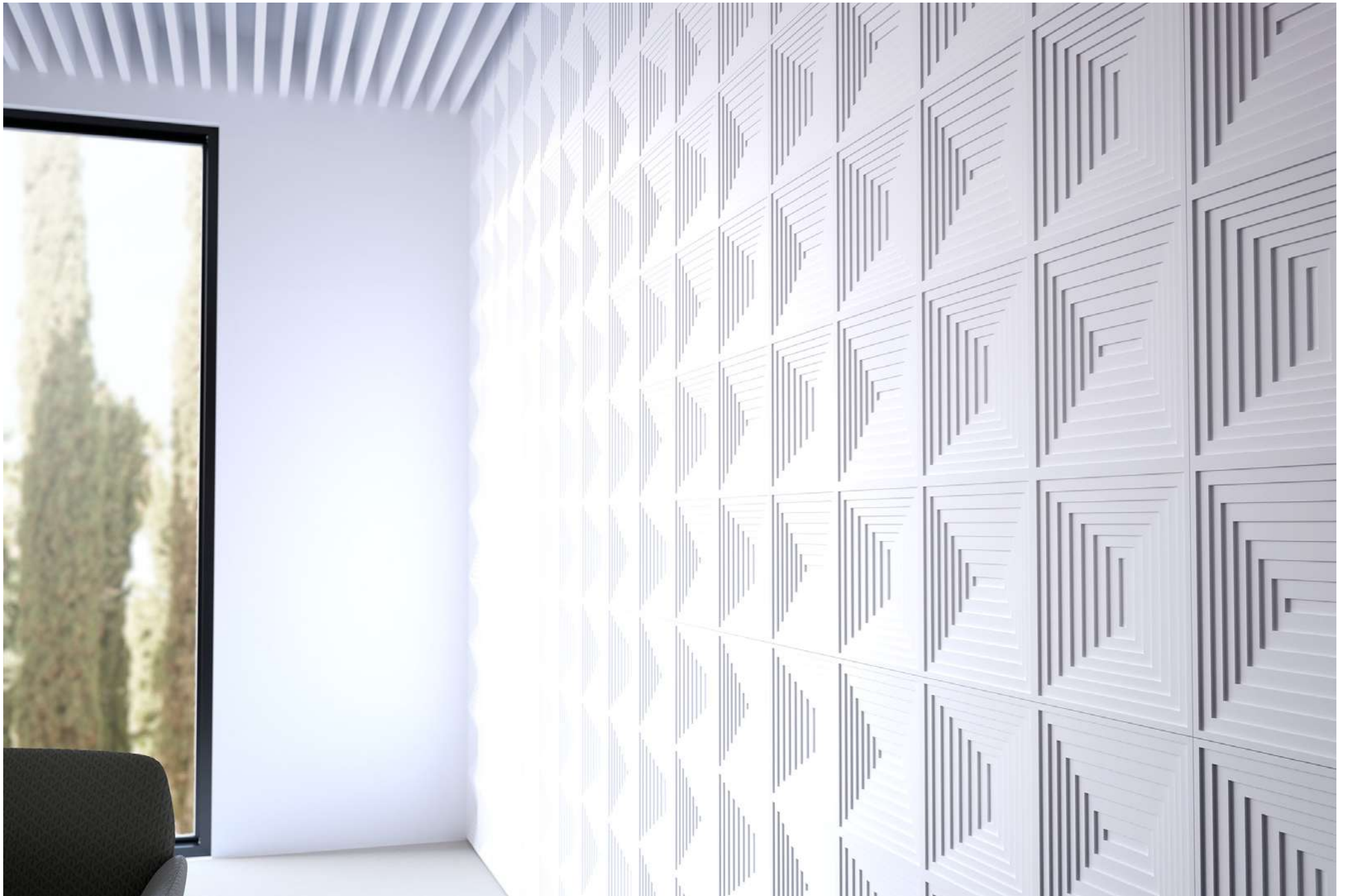

INNER LX-748 BLANCO



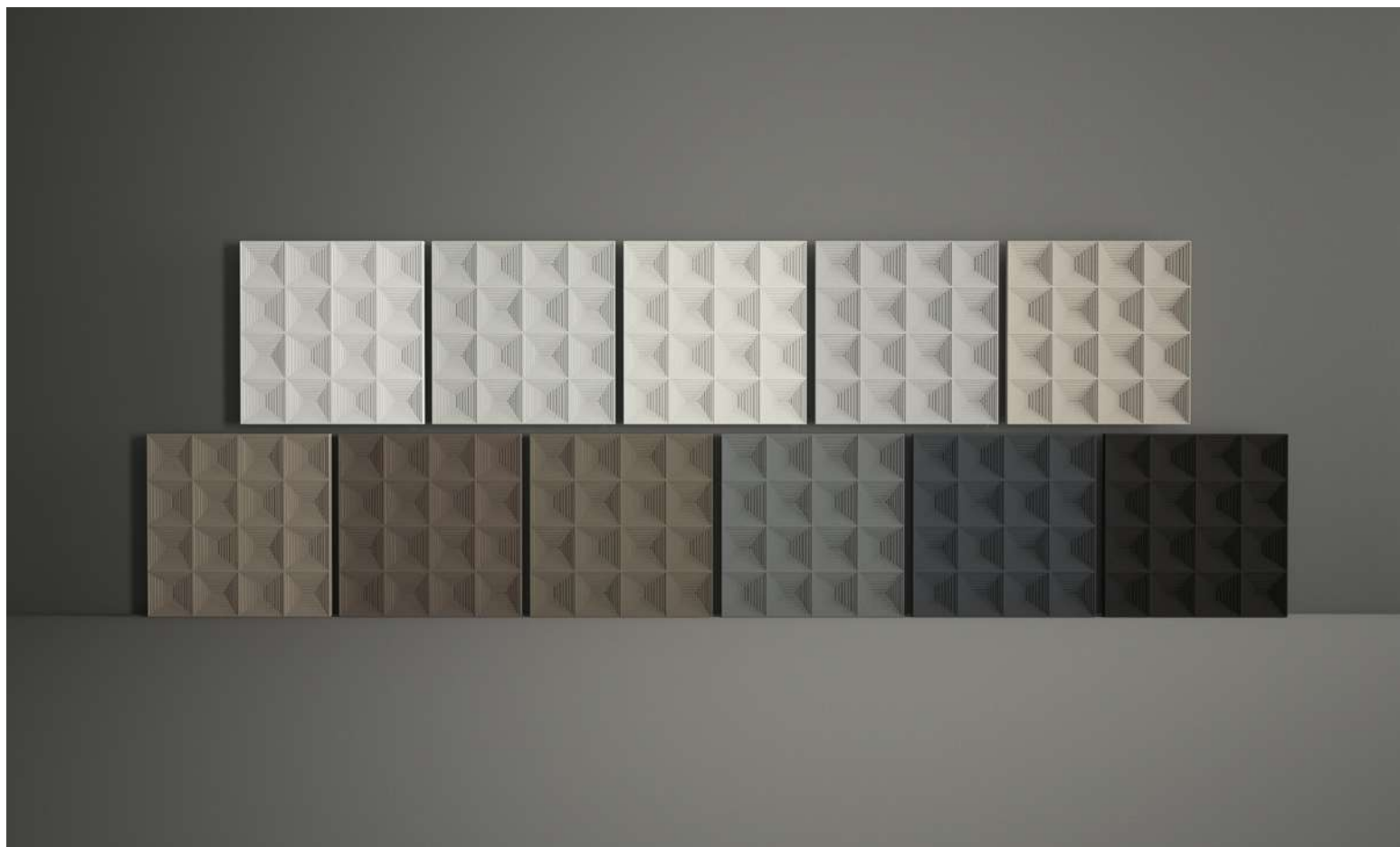

INNER LX-748 BLANCO



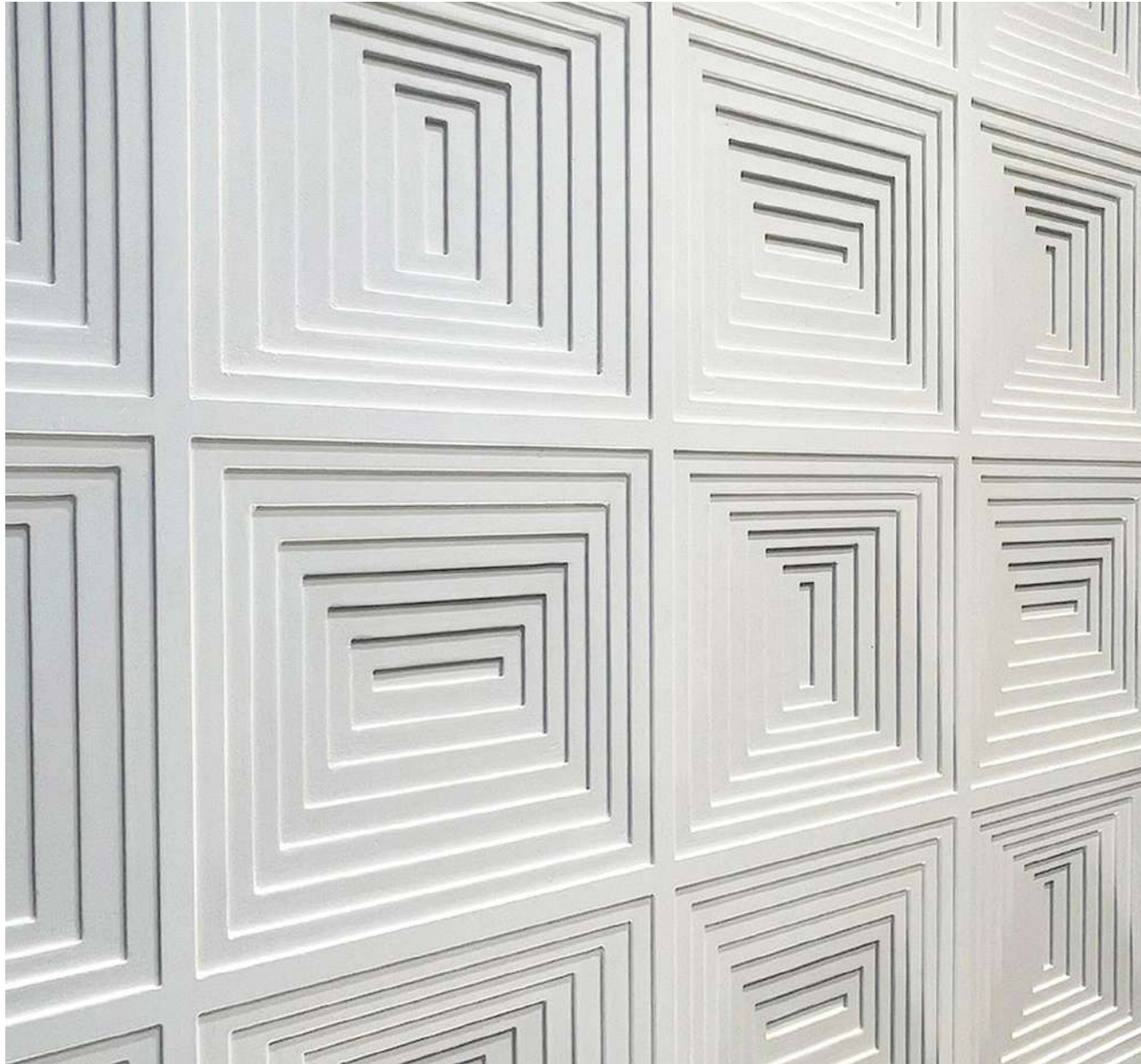

INNER LX-748 BLANCO

Arquitek INNER

Medidas en cm. / Measures in cm.

Las medidas pueden variar +/-1cm / Measurements may vary +/-1cm

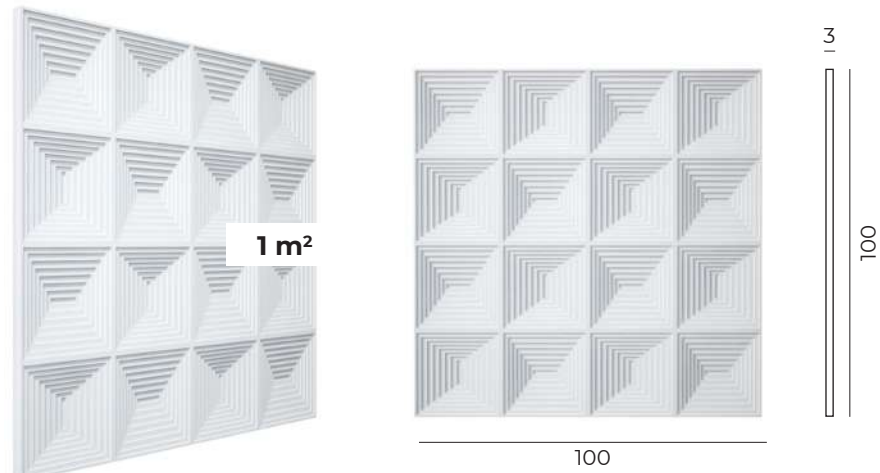



*SE PUEDEN COMBINAR CON NUESTROS PERFILES / *CAN BE COMBINED WITH OUR PROFILES

Acabado de Colores / Finished Colours

- | | | | |
|-----------------------------|--------------------------------|--------------------------------|---------------------------------|
| 1
BLANCO
WHITE | 15
HUESO
BONE | 2
CREMA
CREAM | 3
CEMENTO
CONCRETE |
| 4
ARENA
SAND | 5
CAMEL
CAMEL | 16
TABACO
TOBACCO | 6
PLOMO
LEAD |
| 7
GRIS
GREY | 8
MARENGO
MARENGO | 9
NEGRO
BLACK | |

*Ver especificaciones de acabados: página 16-17 /
*See finish specifications: page 16-17

CALIDADES / QUALITIES	REFERENCIA / CODE	DESCRIPCIÓN / DESCRIPTION	KG.
		LX-748	Panel INNER

LX: 12/13 Kg

Kg. pueden variar +/- / Kg. may vary +/-

RINN



RINN

Panel en un solo tamaño, con un diseño original y creativo y con un acabado imitación cemento totalmente realista.

Panel in a single size, with an original and creative design and a totally realistic cement imitation finish.

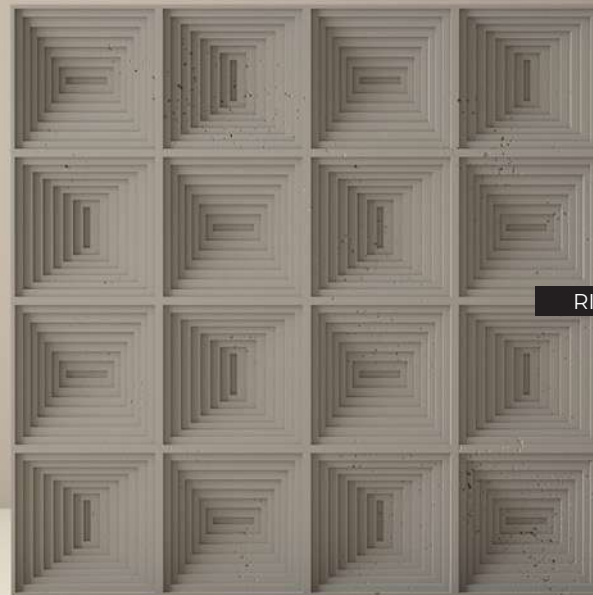

RINN PR-749 IMITACIÓN CEMENTO



RINN PR-749 IMITACIÓN CEMENTO





RINN PR-749 IMITACIÓN CEMENTO



Arquitek RINN

Medidas en cm. / Measures in cm.

Las medidas pueden variar +/-1cm / Measurements may vary +/-1cm

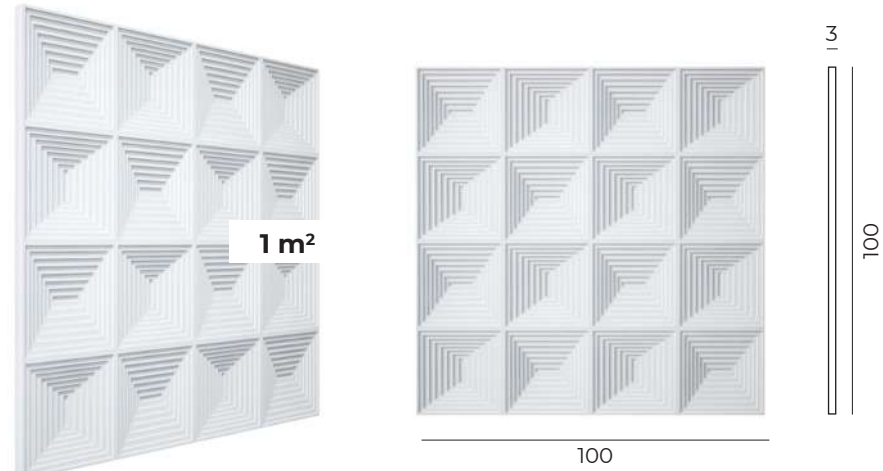





*SE PUEDEN COMBINAR CON NUESTROS PERFILES / *CAN BE COMBINED WITH OUR PROFILES

Acabado de Colores / Finished Colours



IMITACIÓN CEMENTO
IMITATION CONCRETE

*Ver especificaciones de acabados: página 16-17 /
*See finish specifications: page 16-17

CALIDADES / QUALITIES	REFERENCIA / CODE	DESCRIPCIÓN / DESCRIPTION	KG.
		PR-749	Panel RINN
		LX-749	Panel RINN

PR: 9 Kg

LX: 12/13 Kg

Kg. pueden variar +/- / Kg. may vary +/-

BLOM



BLOM

Panel elegante y de gran belleza. Diseñado en un solo tamaño con una amplia gama de colores a combinar.

Elegant and beautiful panel. Designed in one size with a wide range of colours to match.

ECO
LUXER



BLOM LX-750 PLOMO



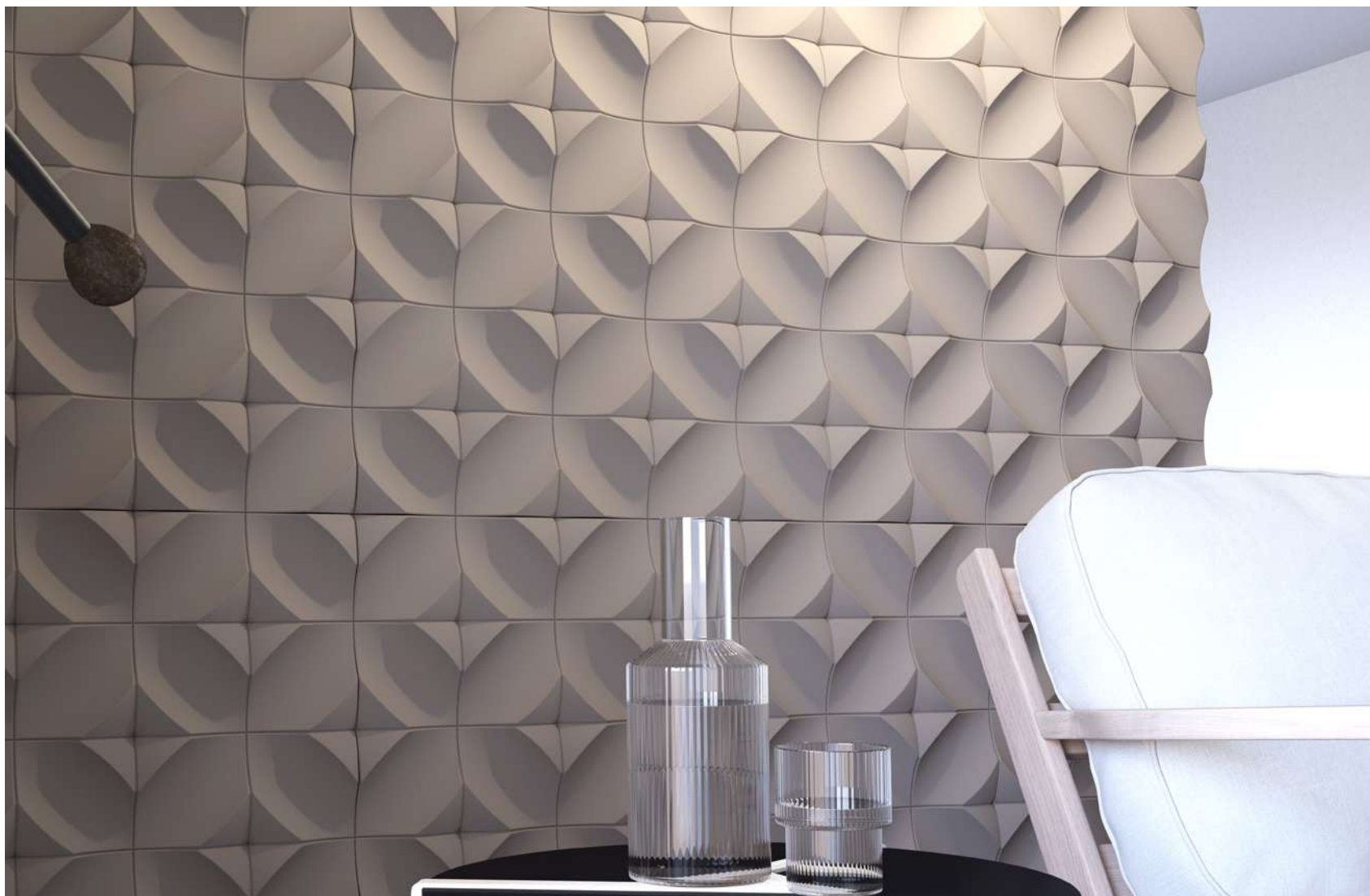



BLOM LX-750 ARENA

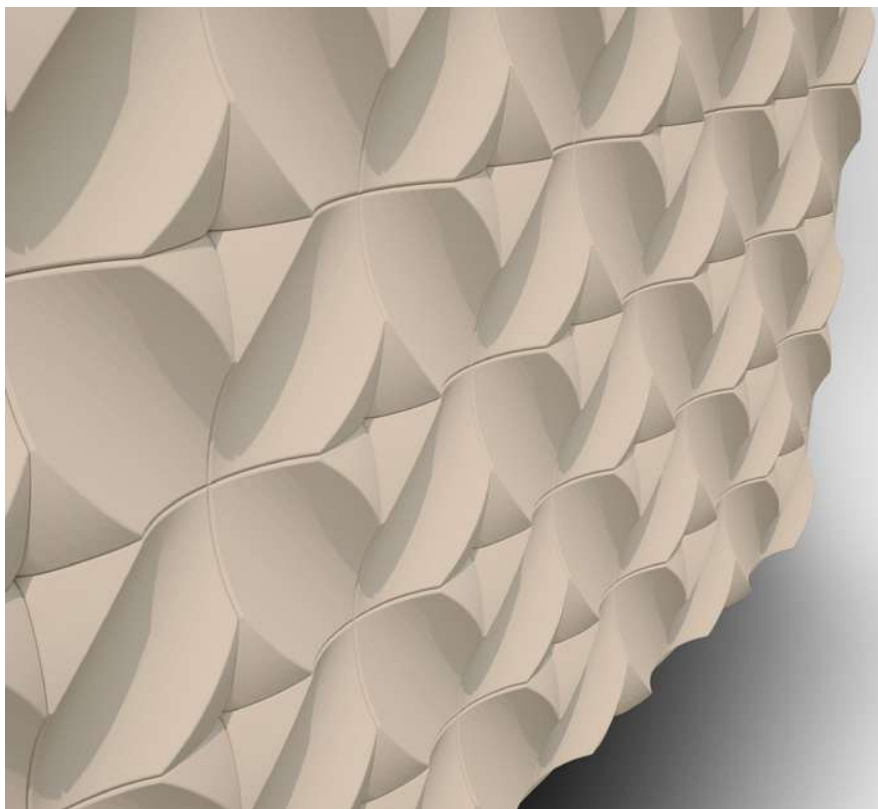

BLOM LX-750 BLANCO

Arquitek BLOM

Medidas en cm. / Measures in cm.

Las medidas pueden variar +/-1cm / Measurements may vary +/-1cm

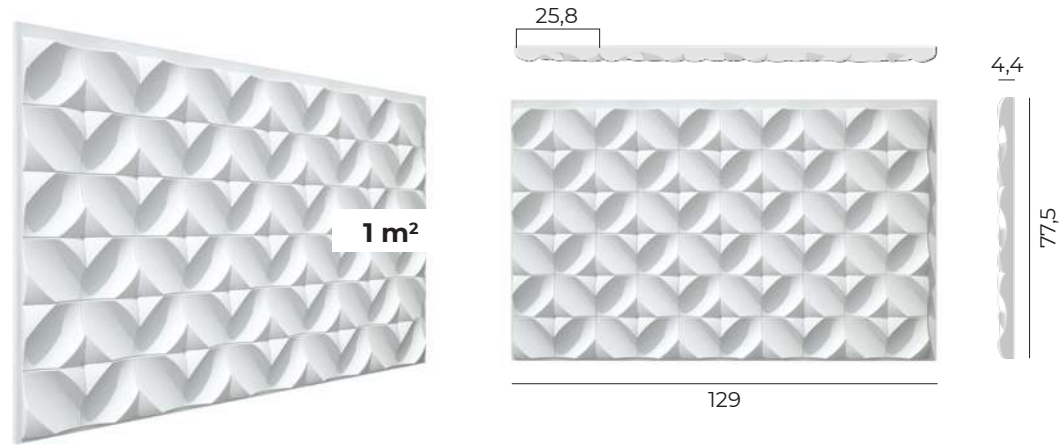

*SE PUEDEN COMBINAR CON NUESTROS PERFILES / *CAN BE COMBINED WITH OUR PROFILES

Acabado de Colores / Finished Colours



*Ver especificaciones de acabados: página 16-17 /
*See finish specifications: page 16-17

CALIDADES / QUALITIES	REFERENCIA / CODE	DESCRIPCIÓN / DESCRIPTION	KG.
		LX-750	Panel BLOM

LX: 12/13 Kg

Kg. pueden variar +/- / Kg. may vary +/-

VITA



VITA

Panel atractivo y moderno, formado por cubos en varias alturas que hacen de él un panel decorativo extraordinario.

Attractive and modern panel, made up of cubes in various heights, making it an extraordinary decorative panel.

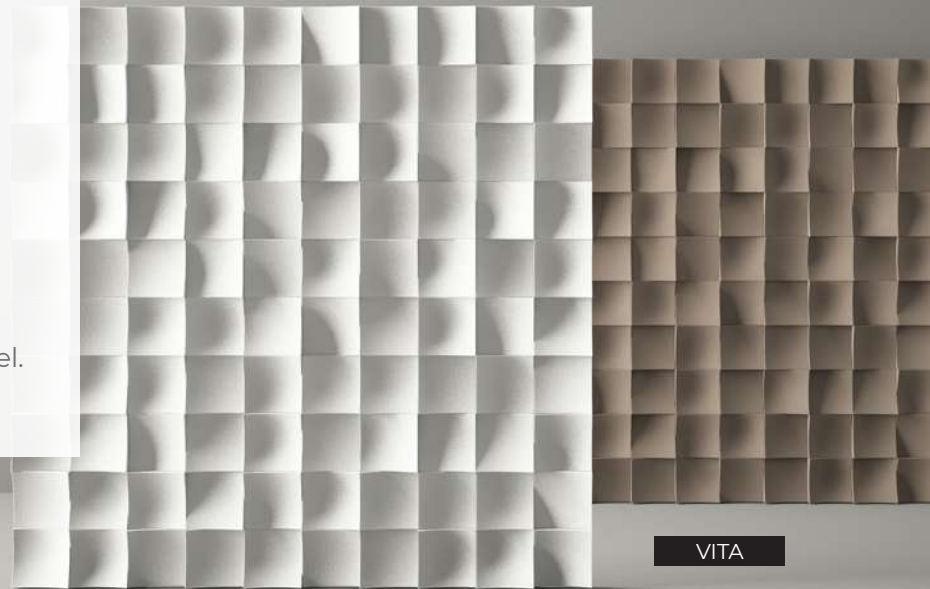

VITA

VITA LX-751 ARENA



VITA LX-751 TABACO

VITA LX-751 BLANCO



VITA LX-751 HUESO



Arquitek VITA

Medidas en cm. / Measures in cm.

Las medidas pueden variar +/-1cm / Measurements may vary +/-1cm

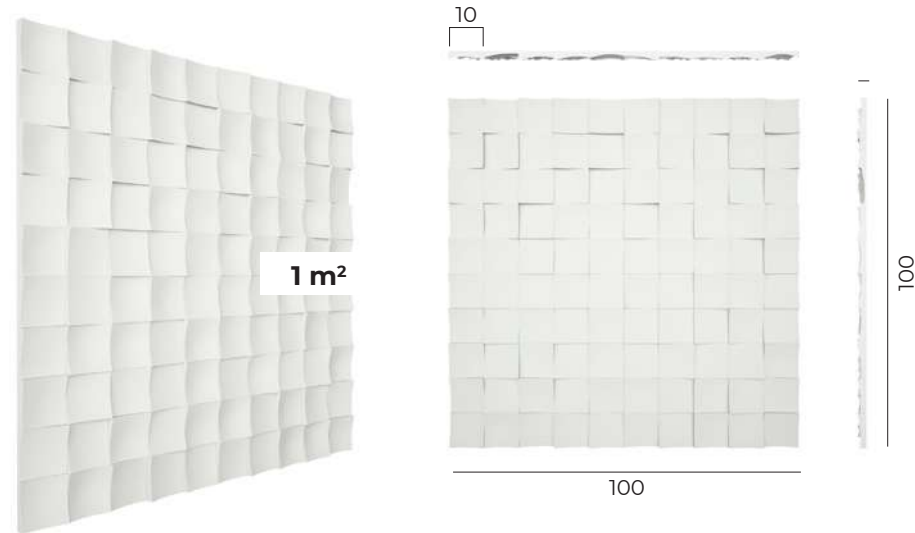

*SE PUEDEN COMBINAR CON NUESTROS PERFILES / *CAN BE COMBINED WITH OUR PROFILES

Acabado de Colores / Finished Colours

- | | | | |
|-----------------------------|--------------------------------|--------------------------------|---------------------------------|
| 1
BLANCO
WHITE | 15
HUESO
BONE | 2
CREMA
CREAM | 3
CEMENTO
CONCRETE |
| 4
ARENA
SAND | 5
CAMEL
CAMEL | 16
TABACO
TOBACCO | 6
PLOMO
LEAD |
| 7
GRIS
GREY | 8
MARENGO
MARENGO | 9
NEGRO
BLACK | |

*Ver especificaciones de acabados: página 16-17 /
*See finish specifications: page 16-17



CALIDADES / QUALITIES	REFERENCIA / CODE	DESCRIPCIÓN / DESCRIPTION	KG.
	LX-751	Panel VITA	LX: 12/13 Kg

Kg. pueden variar +/- / Kg. may vary +/-

PERFILES



PERFILES

Diseñados para combinar con los modelos de la Colección Arquitek. Podrás formar zócalos, separaciones intermedias, terminaciones, marcos perimetrales sobre una pared, etc.

Designed to combine with the models in the Arquitek Collection. You can form skirting boards, intermediate partitions, endings, perimeter frames on a wall, etc.



PERFIL L



PERFIL M





PERFIL L LX-PLL BLANCO

PERFIL M LX-PML MARENGO

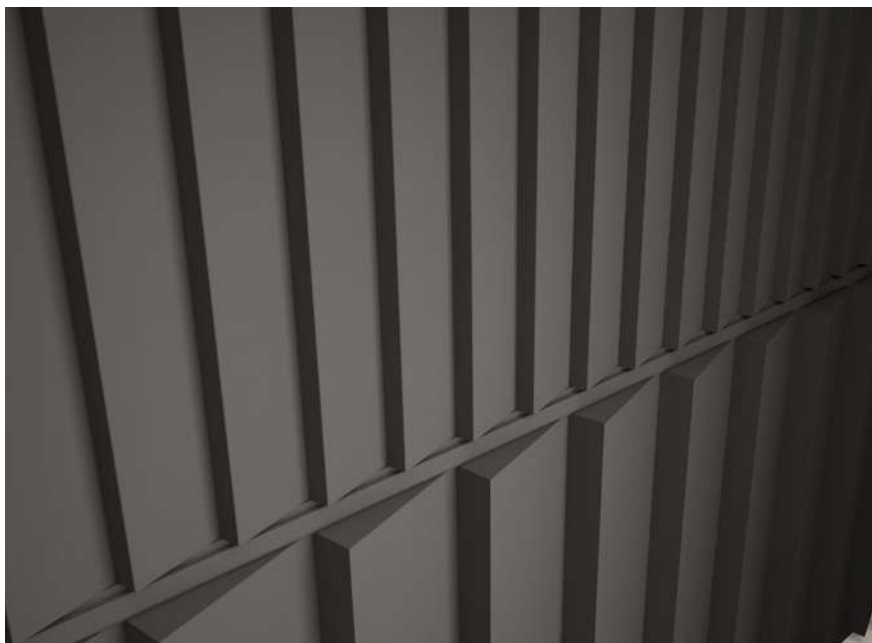

PERFIL L y M LX-PLL BLANCO



Arquitek PERFILES

Medidas en cm. / Measures in cm.

Las medidas pueden variar +/-1cm / Measurements may vary +/-1cm

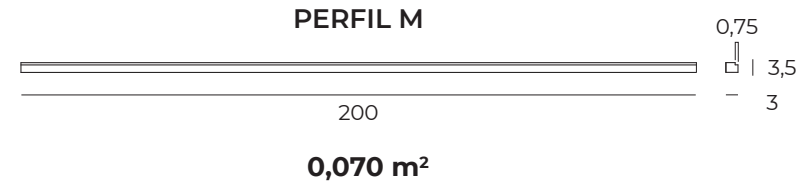
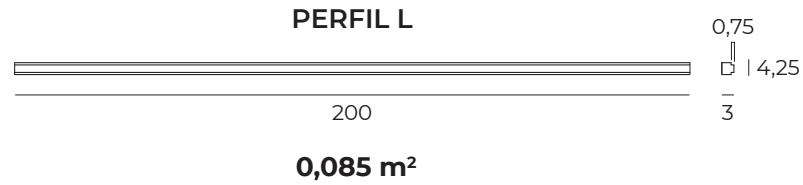

*PARA COMBINAR CON NUESTROS PANELES / *TO COMBINE WITH OUR PANELS

Acabado de Colores / Finished Colours

1 BLANCO WHITE	15 HUESO BONE	2 CREMA CREAM	3 CEMENTO CONCRETE
4 ARENA SAND	5 CAMEL CAMEL	16 TABACO TOBACCO	6 PLOMO LEAD
7 GRIS GREY	8 MARENGO MARENGO	9 NEGRO BLACK	
			
IMITACIÓN CEMENTO IMITATION CONCRETE			

*Ver especificaciones de acabados: página 16-17 /
*See finish specifications: page 16-17



CALIDADES /
QUALITIES



REFERENCIA /
CODE

LX-PLL
LX-PML

DESCRIPCIÓN
DESCRIPTION

Perfil L
Perfil M

KG.

LX: 4 Kg
LX: 3 Kg

Kg. pueden variar +/- / Kg. may vary +/-

Información Técnica

Technical Information

PANELPIEDRA® se reserva el derecho a cambiar los modelos, colores, tamaños, envases y cajas sin previo aviso.

Todos los pesos y dimensiones mencionadas son en cm y se muestran con la mayor precisión posible, pero pueden diferir hasta 2% por la expansión y la contracción durante la producción.

Las fotografías de este Catálogo se crean en lugares del proyecto y en estudios, algunos incluso podrían ser infografías. Las diferencias en la exposición de la luz y la impresión en papel pueden causar que los productos y los colores se vea diferente que en la realidad. Para verificar acabados y texturas utilicen el Servicio de Muestras.

PANELPIEDRA® reserves the right to change models, colours, sizes, packaging and boxes without prior notice.

All weights and dimensions mentioned are in centimetres and are shown as accurately as possible but may differ up to 2% +/- due to expansion and contraction during production.

The photographs in this Catalogue are created on project sites and in studios, some could even be infographics. Differences in light exposure and printing on paper may cause products and colours to appear different than the real thing. To check finishes and textures use the Samples Service.

SÍMBOLOS UTILIZADOS EN ESTE CATÁLOGO / SYMBOLS USED IN THE CATALOGUE



POLIURETANO+PIEDRA
POLYURETHANE+STONE



PIEDRA ALIGERADA
STONE LIGHT



PANEL PARA INTERIOR
INDOOR PANEL



PANEL PARA EXTERIOR E INTERIOR
PANEL FOR OUTDOOR AND INDOOR USE

Garantía

Warranty



Esta garantía cubre las posibles deficiencias o problemas del producto ocasionadas por mala fabricación o materiales defectuosos. Esta garantía no cubre todas aquellas deficiencias o problemas ocasionados por negligencias derivadas de su uso o instalación, así como los daños y perjuicios que estos pudieran ocasionar. Esta garantía no cubre la mano de obra o desplazamiento en caso de negligencias derivadas de su uso o instalación. En caso de incidencia, deberá aportar en el establecimiento de compra acompañado de nuestra garantía, la factura de compra original junto con imágenes descriptivas de la incidencia.

PANELPIEDRA® pone a su disposición en caso de requerimiento, todos los ensayos UNE 1427:2006 y AI:2010.

This guarantee covers possible product deficiencies or problems caused by poor manufacturing or materials. This guarantee does not cover all those deficiencies or problems caused by negligence derived from its use or installation, as well as the damages that these could cause. This guarantee does not cover labour or displacement in case of negligence derived from its use or installation. In the event of an incident, you must provide the original purchase invoice together with descriptive images of the incident at the purchase establishment accompanied by this guarantee.

PANELPIEDRA® puts at your disposal in case of requirement, all tests UNE 1427:2006 and AI:2010.

Condiciones de venta

Sales Terms

PEDIDOS

Todos los pedidos deberán ser por escrito (Correo electrónico o mediante nuestro delegado comercial). Las anulaciones o variaciones de pedidos no se admitirán una vez que éstos hayan entrado en fabricación.

TARIFA

Esta tarifa anula a las anteriores, los precios están sujetos a posibles variaciones motivados por cambio de precios de materias primas, situaciones de mercado etc.

DESCUENTOS

Se realizará el % correspondiente en toda la tarifa.

PEDIDO MÍNIMOS

Los pedidos mínimos serán de 60 euros y siempre se remitirán a portes debidos.

FORMAS DE PAGO

El pago en el primer pedido se realizará al contado anticipado por transferencia bancaria (No se admitirán excepciones).

En los siguientes pedidos la financiación se realizará mediante giro bancario (siempre sujeto a los informes financieros remitidos por nuestro departamento financiero y siempre respetando el plazo que establece la ley de morosidad).

VARIOS GIROS

No se fraccionará los giros inferiores a 500 euros.

PORTES

El Importe del Coste del Transporte de todos los Pedidos de Península y Baleares irán siempre por cuenta del cliente sea cual sea el importe del Pedido. No se establece pedido mínimo.

DEVOLUCIONES DE MATERIAL

No se admitirán devoluciones sin acuerdo previo y consentimiento de fábrica. Cualquier incidencia en la entrega de la mercancía rogamos lo hagan constar en la PDA del Transporte y en el Albarán, de no ser así dispone de un plazo de 24 horas para hacer efectiva la reclamación. No se admitirán devoluciones por sobrantes de material, por errores elección de color o modelo y en ningún caso después de los 30 días naturales de su entrega.

ORDERS

All orders must be sent in writing (Email or through our sales representative). Cancellations or variations of orders will not be accepted once they have entered production.

RATE

This rate cancels the previous ones, the prices are subject to possible variations motivated by changes in the prices of raw materials, market situations, etc.

DISCOUNTS

The corresponding percentage (%) will be made in the entire rate.

MINIMUM ORDER

The minimum orders will be 60 euros and will always be ex-works.

PAYMENT METHODS

Payment in the first order will be made in advance at order by bank transfer (no exceptions will be accepted).

The following orders to be paid before departure of the goods or upon receipt, but only if granted by our financial department in advance and always respecting the term established by the delinquency law).

VARIOUS GIROS

Spanish giros of less than 500 euros will not be split.

POSTAGE

The cost of transport will always be borne by the customer whatever the amount of the order. No minimum qty is required.

MATERIAL RETURNS

Returns will not be accepted without prior agreement and factory consent. Any incident in the delivery of the merchandise, please advise on the delivery note of the transport, otherwise you have a period of 24 hours to make the claim effective. Returns will not be accepted due to excess material, colour or model selection errors and in no case after 30 calendar days of delivery. No claims will be accepted on materials already installed.



PANELPIEDRA®
SINCE 1974

Polígono Industrial Municipal
Vial Transversal, 2
31500 Tudela (Navarra) Spain
Tlf: +34 941 181 091

www.panelpiedra.com

